



ITT

Lowara

SVI Series

2, 4, 8, 16

33, 46, 66, 92

Submersible Vertical Electric
Pumps equipped with IE2
motors complying
with Regulation
(EC) no. 640/2009

50 Hz



Engineered for life



ITT

Lowara

SVI SERIES HYDRAULIC PERFORMANCE RANGE AT 50 Hz

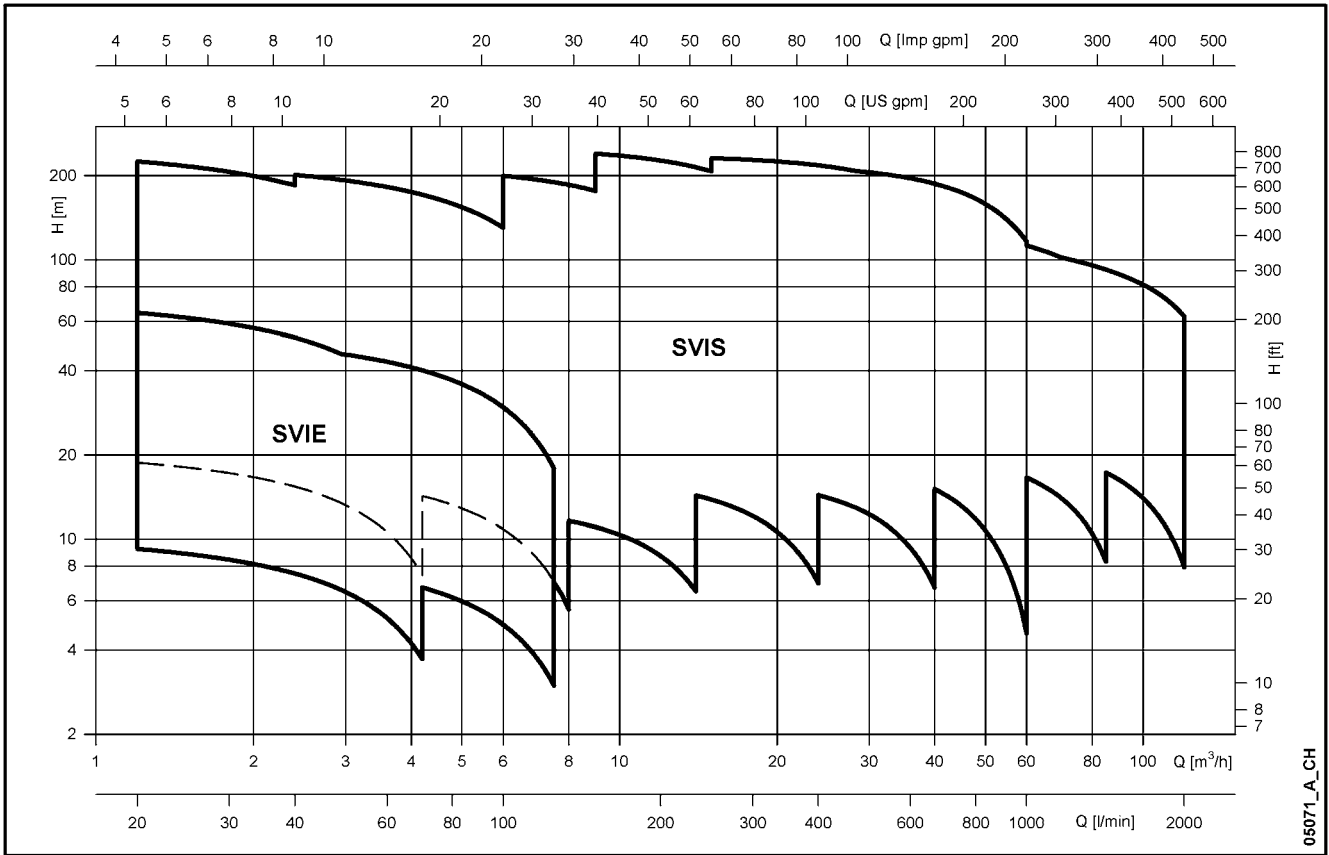

05071_A_CH



CONTENTS

Specifications SVI Series	5
Characteristics of SVI 2, 4, 8, 16 Series	6
Characteristics of SVI 33, 46, 66, 92 Series	6
General Characteristics SVI Series	7
Identification Code SVI Series	8
SVI 2, 4 Series, Electric Pump Cross Section and Main Components	10
SVI 2, 4, 8, 16 Series, Electric Pump Cross Section and Main Components	11
SVI 33, 46, 66, 92 Series, Electric Pump Cross Section and Main Components	12
SVI Mechanical Seals	13
Motors	15
Hydraulic Performance Range SVI Series, 50 Hz	19
Table of Hydraulic Performances SVI Series, 50 Hz	20
Dimensions and Weights SVI Series	24
Operating Characteristics SVI Series, 50 Hz	25
Dimensions of flanges	44
Installation	45
Technical Appendix	47



Lowara

Submersible Vertical Electric pumps

SVI Series

MARKET SECTORS

INDUSTRIAL, CIVIL.

APPLICATIONS

- Pumping of coolants, lubricants and condensate.
- Machine tools, welders, engine test stands.
- Cooling systems.
- Washing systems.
- Boosters.



SPECIFICATIONS PUMP

SVI is a vertical-axis pump with submersible body, equipped with standard motor (for S and N versions).

- **Delivery:** up to 120 m³/h.
- **Head:** up to 240 m.
- **Liquid temperature** for the standard versions:
 - from -10°C to +90°C for S and N versions with coupling.
 - from -10°C a +60°C for close-coupled E versions.
- Maximum ambient temperature: +40°C.
- **Mechanical seal** in Ceramic/Carbon/FPM for the close-coupled E version and in Silicon Carbide/Carbon/FPM for S and N versions with coupling. For SVI 33-46-66-92 models, mechanical seal can be replaced without removing the motor from the pump.
- Tank coupling flange in compliance with EN 12157 (ex DIN 5440) for SVI 2-4 models.
- Standard installation in vertical position; horizontal installation on request.
- These pumps can handle clean liquids free of abrasive substances or fibres, with kinematic viscosity up to 37mm²/sec, with suitably sized motor.
- Minimum level of suction liquid: 25 mm for SVI 2-4-8-16 models and 80 mm for SVI 33-46-66-92.

- Base in the suction side with filter in order to avoid damages due to solids entrance.
- Tested in compliance with ISO 9906 Annex A.
- Direction of rotation: clockwise looking at the pump from the top down (marked with an arrow on the adapter and on the coupling).
- Longer pump columns (from coupling flange to suction base) are available on request. Possible variants are indicated in each model's dimensions table.

MOTORS

- 2 poles motors with squirrel cage in short circuit, enclosed construction with external ventilation.
- Construction design:
 - Close-coupled for E version.
 - Standard motor for S and N versions.
- **Standard supplied IE2 motors are compliant with Regulation (EC) no. 640/2009.**
- IP55 **protection.**
- Class 155 (F) **Insulation.**
- Performances according to EN 60034-1.
- Standard voltage:
 - Three-phase version: 220-240/380-415 V, 50 Hz for power up to 3 kW, 380-415/660-690 V, 50 Hz for power above 3 kW.

CHARACTERISTICS OF SVI 2, 4 SERIES (E, EN VERSIONS)

- Vertical pump with submersible body with impellers, diffusers, outer sleeve, suction base and filter made entirely of stainless steel. Adapter with delivery port in cast iron.
- “N” version made entirely of AISI 316 stainless steel.
- Motor with special shaft extension.
- Standard version for temperatures ranging from -10°C to +60°C.

CHARACTERISTICS OF SVI 2, 4, 8, 16 SERIES (S, N VERSIONS)

- Vertical pump with submersible body.
- “S” version with standard motor; impellers, diffusers, outer sleeve, suction base and filter made entirely of stainless steel. Adapter with delivery port in cast iron.
- “N” version with standard motor, made entirely of AISI 316 stainless steel.
- Reduced axial thrusts enable the use of standard motors that are easily found in the market.
- Mechanical seal according to EN 12756 (ex DIN 24960) e ISO 3069.
- Standard version for temperatures ranging from -10°C to +90°C.

CHARACTERISTICS OF SVI 33, 46, 66, 92 SERIES (S, N VERSIONS)

- Vertical pump with submersible body.
- “S” version with standard motor; impellers, diffusers, tie-rods, suction base and filter made entirely of stainless steel. Adapter and upper head in cast iron.
- “N” version with standard motor; made entirely of AISI 316 stainless steel.
- Delivery port can be coupled to counter-flanges, according to EN 1092.
- Four new sizes (SVI 33-46-66-92) entirely re-designed; improved efficiency and performances.
- Motor versions, depending on the model:
 - with standard bearings for powers up to 11 kW.
 - with reinforced bearings, able to support the vertical axial thrust of the pump for powers ≥ 15 kW (SVI3306/2, SVI4604/2, SVI9202 excluded, with standard bearings).
- Balanced mechanical seal (SiC/C/FPM as standard) according to EN 12756 (ex DIN 24960) and ISO 3069, which can be replaced without removing the motor from the pump.
- Standard version for temperatures ranging from -10°C e +90°C.

OPTIONAL FEATURES

- Single-phase version.
- 4 poles version.
- Special voltages.
- 60 Hz frequency.
- Special materials for mechanical seals and gaskets.
- Horizontal installation.

ACCESSORIES

- Adapter ring which allows compatibility with the previous models SVI 30-60 (keeping the same discharge port axle height from the flange and the same centering to the tank).

GENERAL CHARACTERISTICS
2-POLE SVI

	2E	4E	2S	4S	8S	16S	33S	46S	66S	92S
Max efficiency flow (m ³ /h)	3	5,5	3	5,5	10,5	16	33	42	74	92
Flow range (m ³ /h)	1,2÷4,2	2,4÷7,2	1,2÷4,2	2,4÷7,2	6÷14	9÷24	15÷40	22÷60	30÷85	45÷120
Maximum pressure (bar)	8	6	26	23	22	25	24	22	15	13
Motor power (kW)	0,37÷0,9	0,37÷0,9	0,37÷3	0,37÷4	0,75÷7,5	1,1÷15	2,2÷30	3÷30	4÷30	5,5÷30
Max η (%) of pump	42	57	42	59,5	61,5	64,5	76,5	79	78	79,5
Standard temperature (°C)	-10 +60		-10 +90							

svi-2p50-en_a_tc

SVI VERSIONS

	VERSION	HYDRAULIC	UPPER HEAD	DELIVERY PORT
SVI2-4E	CLOSE-COUPLED	AISI 304	CAST IRON	Threaded Rp 3/4
SVI2-4EN	CLOSE-COUPLED	AISI 316	AISI 316	Threaded Rp 3/4
SVI2-4S	WITH COUPLING	AISI 304	CAST IRON	Threaded Rp 1 1/4
SVI2-4N	WITH COUPLING	AISI 316	AISI 316	Threaded Rp 1 1/4
SVI8-16S	WITH COUPLING	AISI 304	CAST IRON	Threaded Rp 2
SVI8-16N	WITH COUPLING	AISI 316	AISI 316	Threaded Rp 2
SVI33-46-66-92S	WITH COUPLING	AISI 304	CAST IRON	Flanged DN 80
SVI33-46-66-92N	WITH COUPLING	AISI 316	AISI 316	Flanged DN 80

svi-vers-2p50-en_a_tc

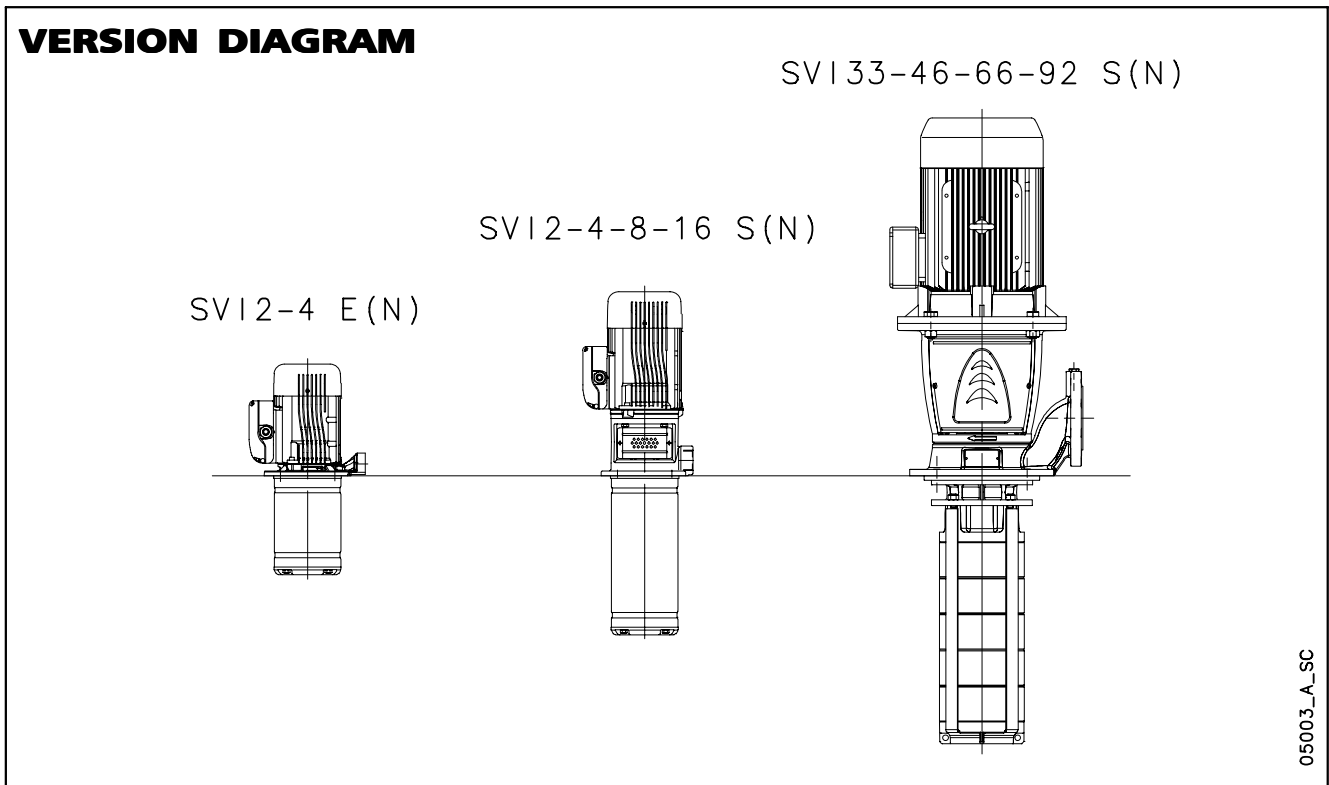



IDENTIFICATION CODE

SVI 2, 4, 8, 16

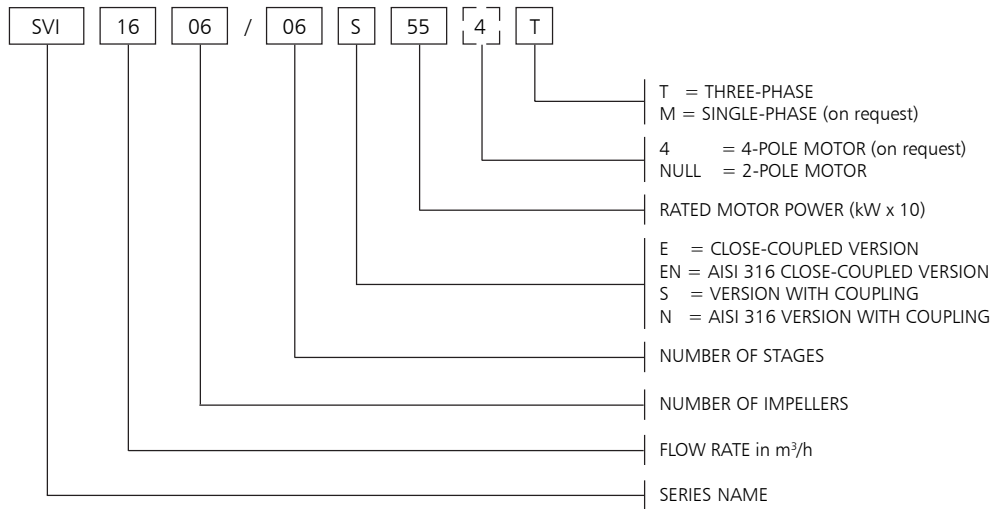

EXAMPLE : SVI1606/06S55T

SVI Series Electric pump, flow rate 16 m³/h, number of impellers 6, number of stages 6, S version with coupling, rated motor power 5,5 kW, 50 Hz version, three-phase.

SVI 33, 46, 66, 92

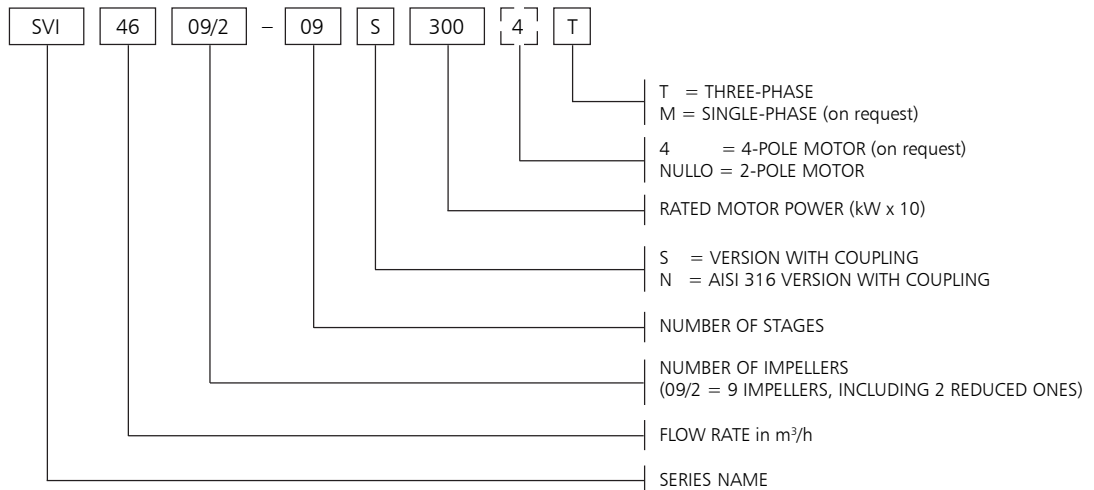

EXAMPLE : SVI4609/2-09S300T

SVI Series Electric pump, flow rate 46 m³/h, number of impellers 9 including 2 reduced ones, number of stages 9, S version with coupling, rated motor power 30 kW, 50 Hz version, three-phase.

RATING PLATE SVI 2, 4 (E, EN)

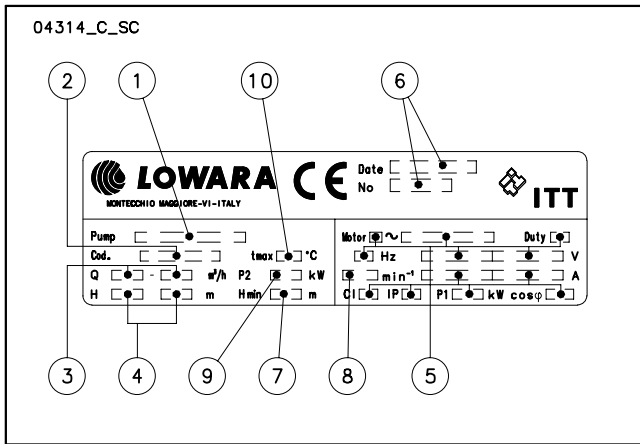

LEGEND

- 1 - Electric pump type
- 2 - Code
- 3 - Delivery range
- 4 - Head range
- 5 - Motor type
- 6 - Date of manufacturing and serial number
- 7 - Minimum head
- 8 - Speed
- 9 - Rated power
- 10 - Maximum operating temperature

SVI 2, 4, 8, 16 (S, N)

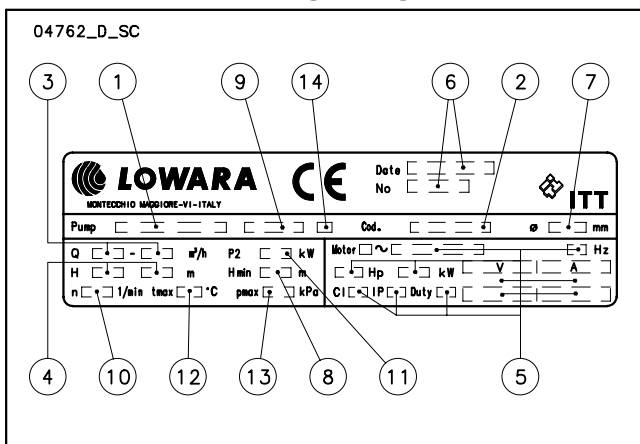

LEGEND

- 1 - Electric pump type
- 2 - Code
- 3 - Delivery range
- 4 - Head range
- 5 - Motor type
- 6 - Date of manufacturing and serial number
- 7 - Impeller diameter
- 8 - Minimum head
- 9 - Mechanical seal material identification code
- 10 - Speed
- 11 - Rated power
- 12 - Maximum operating temperature
- 13 - Maximum operating pressure
- 14 - O-ring material identification code

SVI 33, 46, 66, 92 (S, N)

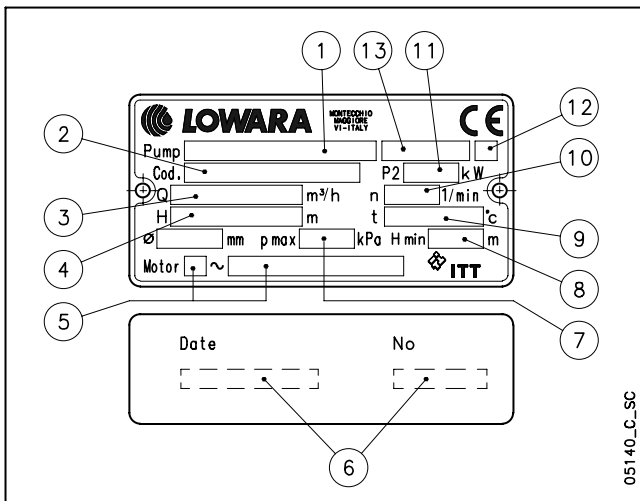

LEGEND

- 1 - Electric pump type
- 2 - Code
- 3 - Delivery range
- 4 - Head range
- 5 - Motor type
- 6 - Date of manufacturing and serial number
- 7 - Maximum operating pressure *
- 8 - Minimum head
- 9 - Maximum operating temperature *
- 10 - Speed
- 11 - Rated power
- 12 - O-ring material identification code
- 13 - Mechanical seal material identification code

* To be verified on pressure/temperature limit diagrams (pag. 14)



SVI 2, 4 (E, EN) SERIES

ELECTRIC PUMP CROSS SECTION AND MAIN COMPONENTS

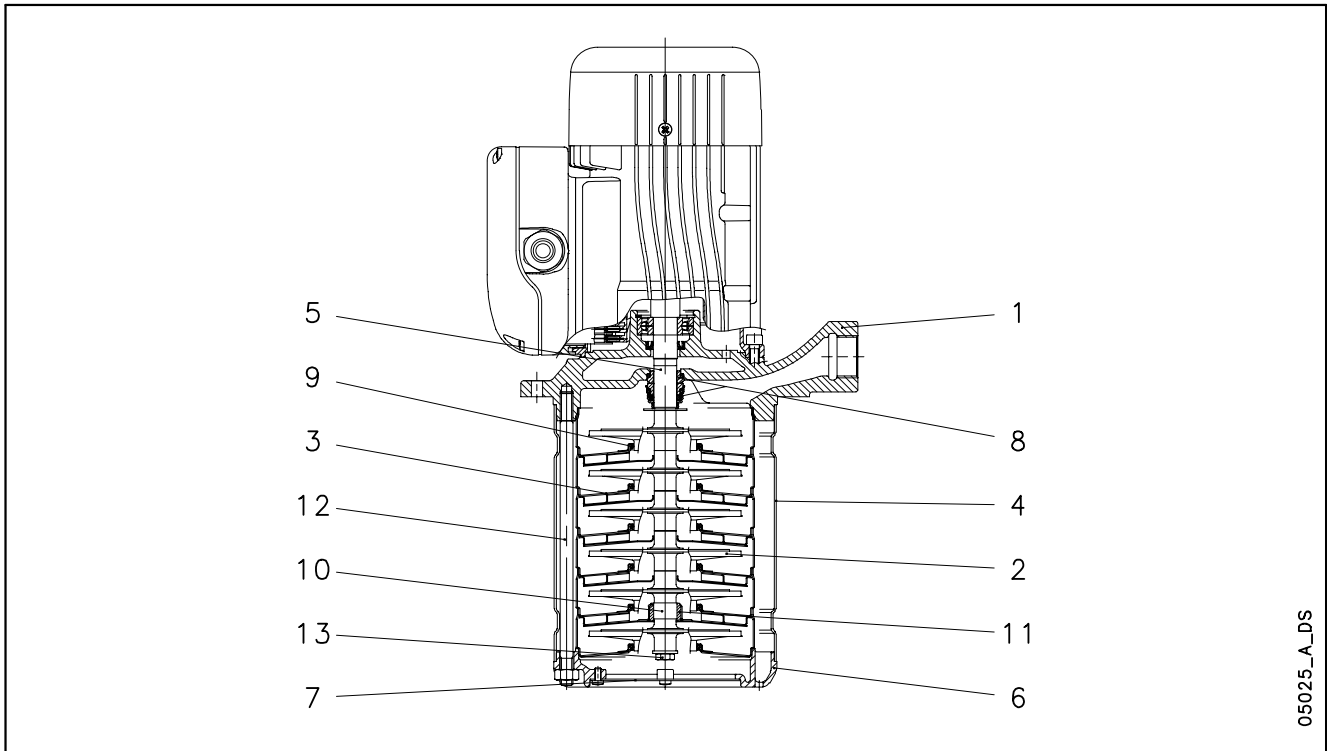

SVI 2, 4 (E VERSIONS)

REF. N.	NAME	MATERIAL	REFERENCE STANDARDS	
			EUROPE	USA
1	Adapter	Cast iron	EN 1561-GJL-200 (JL1030)	ASTM Class 25
2	Impeller	Stainless steel	EN 10088-1-X5CrNi18-10 (1.4301)	AISI 304
3	Diffuser	Stainless steel	EN 10088-1-X5CrNi18-10 (1.4301)	AISI 304
4	Outer sleeve	Stainless steel	EN 10088-1-X2CrNiMo17-12-2 (1.4404)	AISI 316L
5	Shaft	Stainless steel	EN 10088-1-X5CrNi18-10 (1.4301)	AISI 304
6	Suction base	Stainless steel	EN 10213-4-GX5CrNiMo19-11-2 (1.4408)	ASTM CF8M (AISI 316 cast)
7	Strainer	Stainless steel	EN 10088-1-X5CrNiMo17-12-2 (1.4401)	AISI 316
8	Mechanical seal	Ceramic / Carbon / FPM		
9	Elastomers	FPM		
10	Shaft sleeve	Tungsten carbide		
11	Bushing	Ceramic (Alumina)		
12	Tie rods	Stainless steel	EN 10088-1-X5CrNiMo17-12-2 (1.4401)	AISI 316
13	Screws	Stainless steel	EN 10088-1-X5CrNi18-10 (1.4301)	AISI 304

svi2-4-e-en_a_tm

SVI 2, 4 (EN VERSIONS)

REF. N.	NAME	MATERIAL	REFERENCE STANDARDS	
			EUROPE	USA
1	Adapter	Stainless steel	EN 10213-4-GX5CrNiMo19-11-2 (1.4408)	ASTM CF8M (AISI 316 cast)
2	Impeller	Stainless steel	EN 10088-1-X2CrNiMo17-12-2 (1.4404)	AISI 316L
3	Diffuser	Stainless steel	EN 10088-1-X2CrNiMo17-12-2 (1.4404)	AISI 316L
4	Outer sleeve	Stainless steel	EN 10088-1-X2CrNiMo17-12-2 (1.4404)	AISI 316L
5	Shaft	Stainless steel	EN 10088-1-X5CrNiMo17-12-2 (1.4401)	AISI 316
6	Suction base	Stainless steel	EN 10213-4-GX5CrNiMo19-11-2 (1.4408)	ASTM CF8M (AISI 316 cast)
7	Strainer	Stainless steel	EN 10088-1-X5CrNiMo17-12-2 (1.4401)	AISI 316
8	Mechanical seal	Ceramic / Carbon / FPM		
9	Elastomers	FPM		
10	Shaft sleeve	Tungsten carbide		
11	Bushing	Ceramic (Alumina)		
12	Tie rods	Acciaio inox	EN 10088-1-X5CrNiMo17-12-2 (1.4401)	AISI 316
13	Screws	Acciaio inox	EN 10088-1-X5CrNiMo17-12-2 (1.4401)	AISI 316

svi2-4-n-en_a_tm



ITT

Lowara

SVI 2, 4, 8, 16 (S, N) SERIES

ELECTRIC PUMP CROSS SECTION AND MAIN COMPONENTS

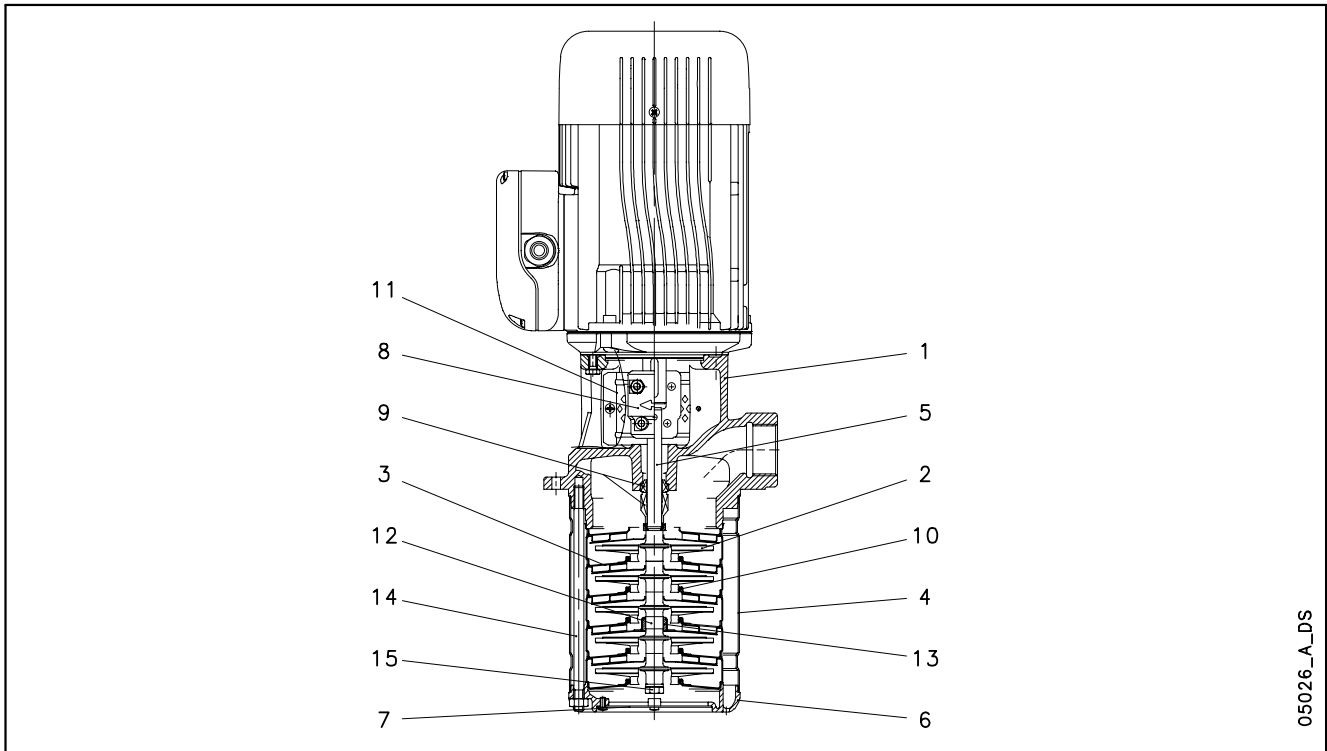

SVI 2, 4, 8, 16 (S VERSIONS)

REF. N.	NAME	MATERIAL	REFERENCE STANDARDS	
			EUROPE	USA
1	Adapter	Cast iron	EN 1561-GJL-250 (JL1040)	ASTM Class 35
2	Impeller	Stainless steel	EN 10088-1-X5CrNi18-10 (1.4301)	AISI 304
3	Diffuser	Stainless steel	EN 10088-1-X5CrNi18-10 (1.4301)	AISI 304
4	Outer sleeve	Stainless steel	EN 10088-1-X2CrNiMo17-12-2 (1.4404)	AISI 316L
5	Shaft	Stainless steel	EN 10088-1-X5CrNi18-10 (1.4301)	AISI 304
6	Suction base	Stainless steel	EN 10213-4-GX5CrNiMo19-11-2 (1.4408)	ASTM CF8M (AISI 316 cast)
7	Strainer	Stainless steel	EN 10088-1-X5CrNiMo17-12-2 (1.4401)	AISI 316
8	Coupling (up to 4 kW)	Aluminium	EN 1706-AC-ALSi11Cu2 (Fe) (AC46100)	-
	Coupling (for higher powers)	Cast iron	EN 1561-GJL-200 (JL1030)	ASTM Class 25
9	Mechanical seal	Silicon carbide / Carbon / FPM		
10	Elastomers	FPM		
11	Coupling protection	Stainless steel	EN 10088-1-X5CrNi18-10 (1.4301)	AISI 304
12	Shaft sleeve	Tungsten carbide		
13	Bushing	Ceramic (Alumina)		
14	Tie rods	Stainless steel	EN 10088-1-X5CrNiMo17-12-2 (1.4401)	AISI 316
15	Screws	Stainless steel	EN 10088-1-X5CrNiMo17-12-2 (1.4401)	AISI 316

svi2-16-s-en_a_tm

SVI 2, 4, 8, 16 (N VERSIONS)

REF. N.	NAME	MATERIAL	REFERENCE STANDARDS	
			EUROPE	USA
1	Adapter	Stainless steel	EN 10213-4-GX5CrNiMo19-11-2 (1.4408)	ASTM CF8M (AISI 316 cast)
2	Impeller	Stainless steel	EN 10088-1-X2CrNiMo17-12-2 (1.4404)	AISI 316L
3	Diffuser	Stainless steel	EN 10088-1-X2CrNiMo17-12-2 (1.4404)	AISI 316L
4	Outer sleeve	Stainless steel	EN 10088-1-X2CrNiMo17-12-2 (1.4404)	AISI 316L
5	Shaft	Stainless steel	EN 10088-1-X5CrNiMo17-12-2 (1.4401)	AISI 316
6	Suction base	Stainless steel	EN 10213-4-GX5CrNiMo19-11-2 (1.4408)	ASTM CF8M (AISI 316 cast)
7	Strainer	Stainless steel	EN 10088-1-X5CrNiMo17-12-2 (1.4401)	AISI 316
8	Coupling (up to 4 kW)	Aluminium	EN 1706-AC-ALSi11Cu2 (Fe) (AC46100)	-
	Coupling (for higher powers)	Cast iron	EN 1561-GJL-200 (JL1030)	ASTM Class 25
9	Mechanical seal	Silicon carbide / Carbon / FPM		
10	Elastomers	FPM		
11	Coupling protection	Stainless steel	EN 10088-1-X5CrNi18-10 (1.4301)	AISI 304
12	Shaft sleeve	Tungsten carbide		
13	Bushing	Ceramic (Alumina)		
14	Tie rods	Stainless steel	EN 10088-1-X5CrNiMo17-12-2 (1.4401)	AISI 316
15	Screws	Stainless steel	EN 10088-1-X5CrNiMo17-12-2 (1.4401)	AISI 316

svi2-16-n-en_a_tm



ITT

Lowara

SVI 33, 46, 66, 92 (S, N) SERIES ELECTRIC PUMP CROSS SECTION AND MAIN COMPONENTS

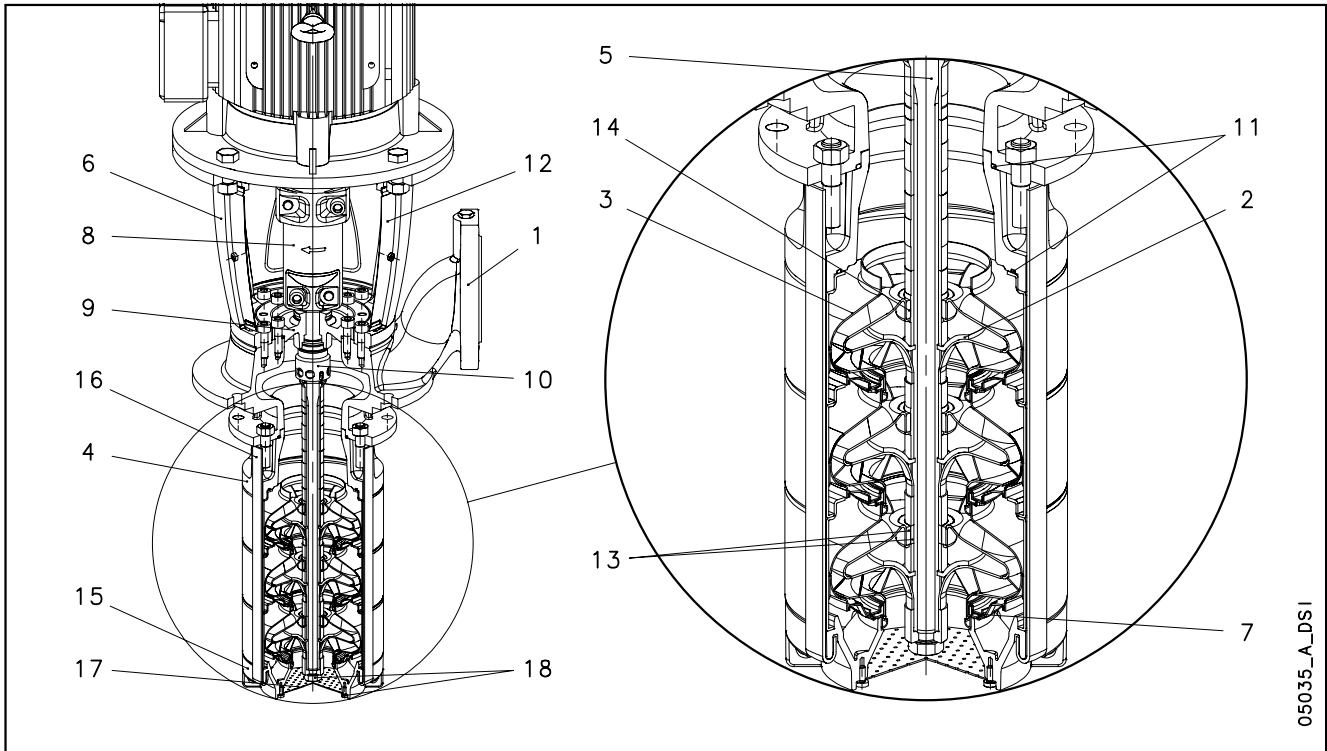

SVI 33, 46, 66, 92 (S VERSIONS)

REF. N.	NAME	MATERIAL	REFERENCE STANDARDS	
			EUROPE	USA
1	Upper head	Cast iron	EN 1561-GJL-250 (JL1040)	ASTM Class 35
2	Impeller	Stainless steel	EN 10088-1-X2CrNiMo17-12-2 (1.4404)	AISI 316L
3	Diffuser	Stainless steel	EN 10088-1-X5CrNi18-10 (1.4301)	AISI 304
4	Adapter	Cast iron	EN 1561-GJL-250 (JL1040)	ASTM Class 35
5	Shaft	Stainless steel	EN 10088-1 - X17CrNi16-2 (1.4057)	AISI 431
6	Motor adapter	Cast iron	EN 1561-GJL-200 (JL1030)	ASTM Class 25
7	Wear ring	Technopolymer PPS		
8	Coupling	Cast iron	EN 1561-GJL-200 (JL1030)	ASTM Class 25
9	Seal housing	Cast iron	EN 1561-GJL-250 (JL1040)	ASTM Class 35
10	Mechanical seal	Silicon carbide / Carbon / FPM		
11	Elastomers	FPM		
12	Coupling protection	Stainless steel	EN 10088-1-X5CrNi18-10 (1.4301)	AISI 304
13	Shaft sleeve and bushing	Tungsten carbide		
14	Bushing for diffuser	Carbon		
15	Suction base	Stainless steel	EN 10213-4-GX5CrNiMo19-11-2 (1.4408)	ASTM CF8M (AISI 316 cast)
16	Tie rods	Stainless steel	EN 10088-1-X5CrNi18-10 (1.4301)	AISI 304
17	Strainer	Stainless steel	EN 10088-1-X5CrNiMo17-12-2 (1.4401)	AISI 316
18	Screws	Stainless steel	EN 10088-1-X5CrNiMo17-12-2 (1.4401)	AISI 316

SVI 33, 46, 66, 92 (N VERSIONS)

svi33-92-s-en_a_tm

REF. N.	NAME	MATERIAL	REFERENCE STANDARDS	
			EUROPE	USA
1	Upper head	Stainless steel	EN 10213-4-GX5CrNiMo19-11-2 (1.4408)	ASTM CF8M (AISI 316 cast)
2	Impeller	Stainless steel	EN 10088-1-X2CrNiMo17-12-2 (1.4404)	AISI 316L
3	Diffuser	Stainless steel	EN 10088-1-X2CrNiMo17-12-2 (1.4404)	AISI 316L
4	Adapter	Stainless steel	EN 10213-4-GX5CrNiMo19-11-2 (1.4408)	ASTM CF8M (AISI 316 cast)
5	Shaft	Duplex stainless steel	EN 10088-1-X2CrNiMoN22-5-3 (1.4462)	UNS S 31803
6	Motor adapter	Cast iron	EN 1561-GJL-200 (JL1030)	ASTM Class 25
7	Wear ring	Technopolymer PPS		
8	Coupling	Cast iron	EN 1561-GJL-200 (JL1030)	ASTM Class 25
9	Seal housing	Stainless steel	EN 10213-4-GX5CrNiMo19-11-2 (1.4408)	ASTM CF8M (AISI 316 cast)
10	Mechanical seal	Silicon carbide / Carbon / FPM		
11	Elastomers	FPM		
12	Coupling protection	Stainless steel	EN 10088-1-X5CrNi18-10 (1.4301)	AISI 304
13	Shaft sleeve and bushing	Tungsten carbide		
14	Bushing for diffuser	Carbon		
15	Suction base	Stainless steel	EN 10213-4-GX5CrNiMo19-11-2 (1.4408)	ASTM CF8M (AISI 316 cast)
16	Tie rods	Stainless steel	EN 10088-1-X2CrNiMo17-12-2 (1.4404)	AISI 316L
17	Strainer	Stainless steel	EN 10088-1-X5CrNiMo17-12-2 (1.4401)	AISI 316
18	Screws	Stainless steel	EN 10088-1-X5CrNiMo17-12-2 (1.4401)	AISI 316

svi33-92-n-en_a_tm

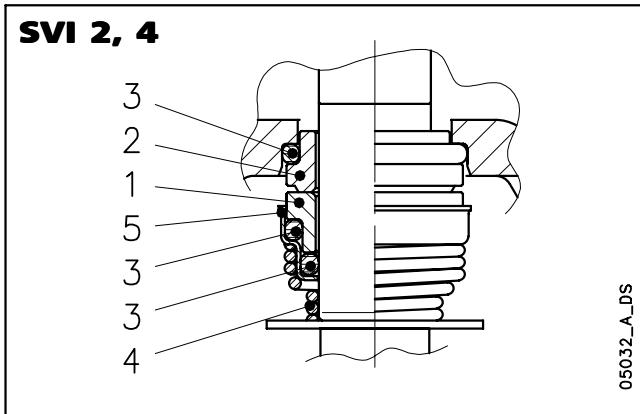
**SVI (E, EN) SERIES
MECHANICAL SEAL, ACCORDING TO EN 12756**

LIST OF MATERIALS

POSITION 1 - 2	POSITION 3	POSITION 4 - 5
V : Ceramic	V : FPM	G : AISI 316
B : Resin impregnated carbon	E : EPDM	
C : Special resin impregnated carbon		
Q ₁ : Silicon Carbide		

svi-e_ten-mec-en_a_tm

SEAL TYPES

TYPE	POSITION					TEMPERATURE (°C)
	1 ROTATING PART	2 STATIONARY PART	3 ELASTOMERS	4 SPRINGS	5 OTHER COMPONENTS	
STANDARD MECHANICAL SEAL						
VBVGG	V	B	V	G	G	-10 +60
OTHER TYPES OF MECHANICAL SEAL						
Q ₁ Q ₁ EGG	Q ₁	Q ₁	E	G	G	-30 +60
Q ₁ CVGG	Q ₁	C	V	G	G	-10 +60
Q ₁ Q ₁ VGG	Q ₁	Q ₁	V	G	G	-10 +60

svi-e_tipi-ten-mec-en_a_tc

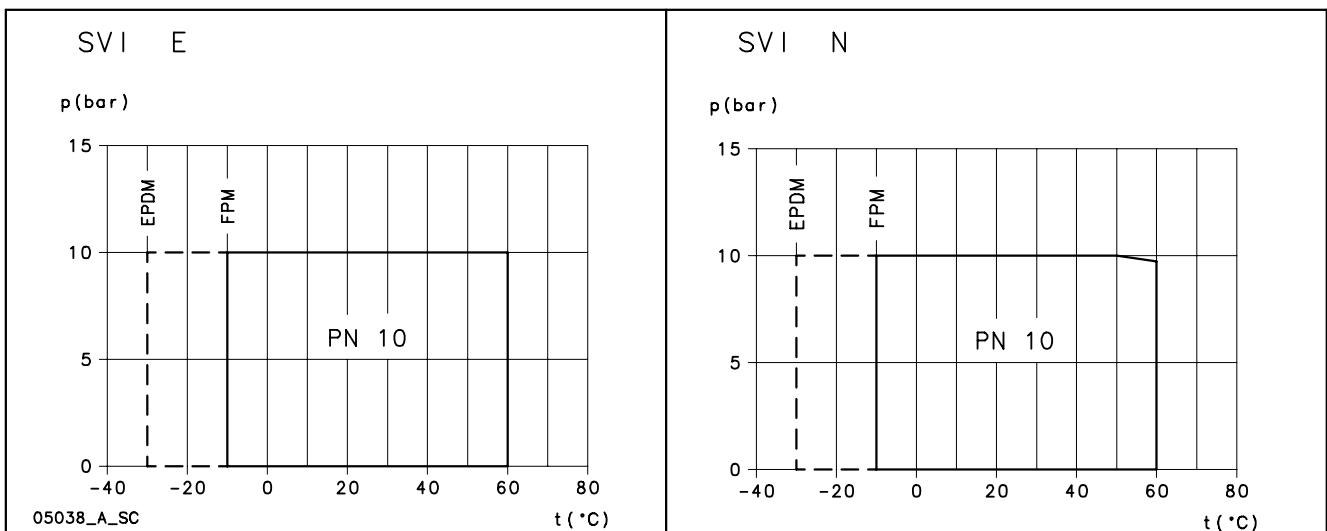
**COMPLETE PUMP PRESSURE / TEMPERATURE OPERATING LIMITS
(WITH ANY OF THE SEALS LISTED ABOVE)**



ITT

Lowara

SVI (S, N) SERIES MECHANICAL SEALS, ACCORDING TO EN 12756

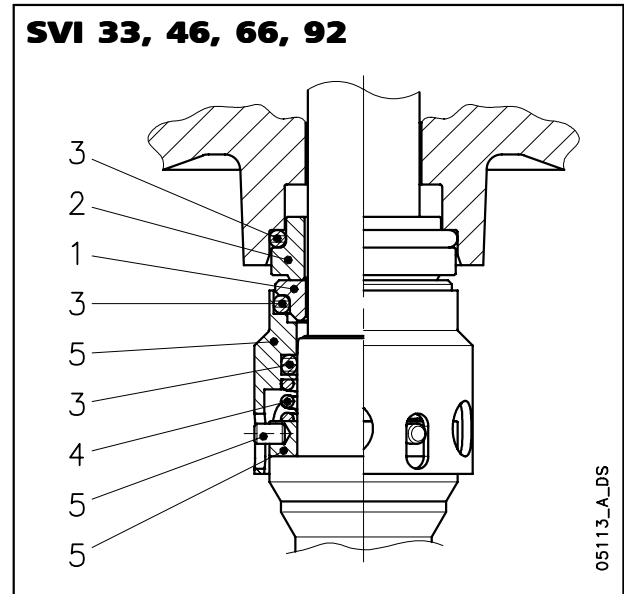
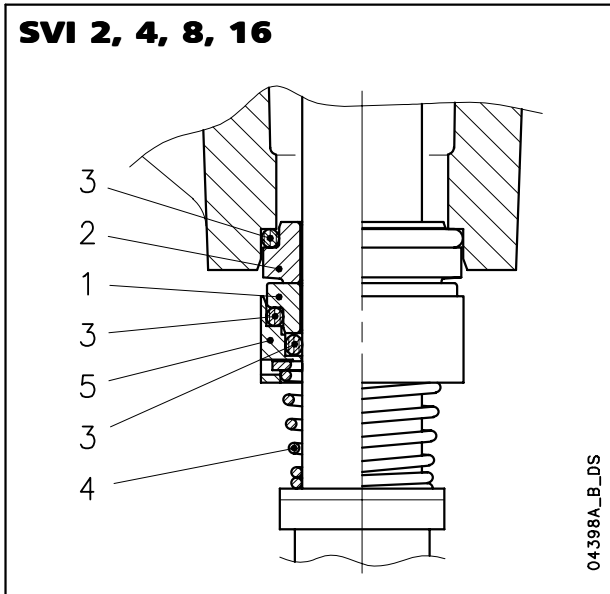

LIST OF MATERIALS

POSITION 1 - 2	POSITION 3	POSITION 4 - 5
Q ₁ : Silicon Carbide	V : FPM	G : AISI 316
B : Resin impregnated carbon	E : EPDM	
	T : PTFE	

SEAL TYPES

svi-s_ten-mec-en_a_tm

TYPE	POSITION					TEMPERATURE (°C)
	1 ROTATING PART	2 STATIONARY PART	3 ELASTOMERS	4 SPRINGS	5 OTHER COMPONENTS	
STANDARD MECHANICAL SEAL						
Q ₁ B V G G	Q ₁	B	V	G	G	-10 +90
OTHER TYPES OF MECHANICAL SEAL						
Q ₁ Q ₁ V G G	Q ₁	Q ₁	V	G	G	-10 +90
Q ₁ Q ₁ E G G	Q ₁	Q ₁	E	G	G	-30 +90
Q ₁ Q ₁ T G G	Q ₁	Q ₁	T	G	G	0 +90

svi-s_tipi-ten-mec-en_a_tc

COMPLETE PUMP PRESSURE / TEMPERATURE OPERATING LIMITS (WITH ANY OF THE SEALS LISTED ABOVE)

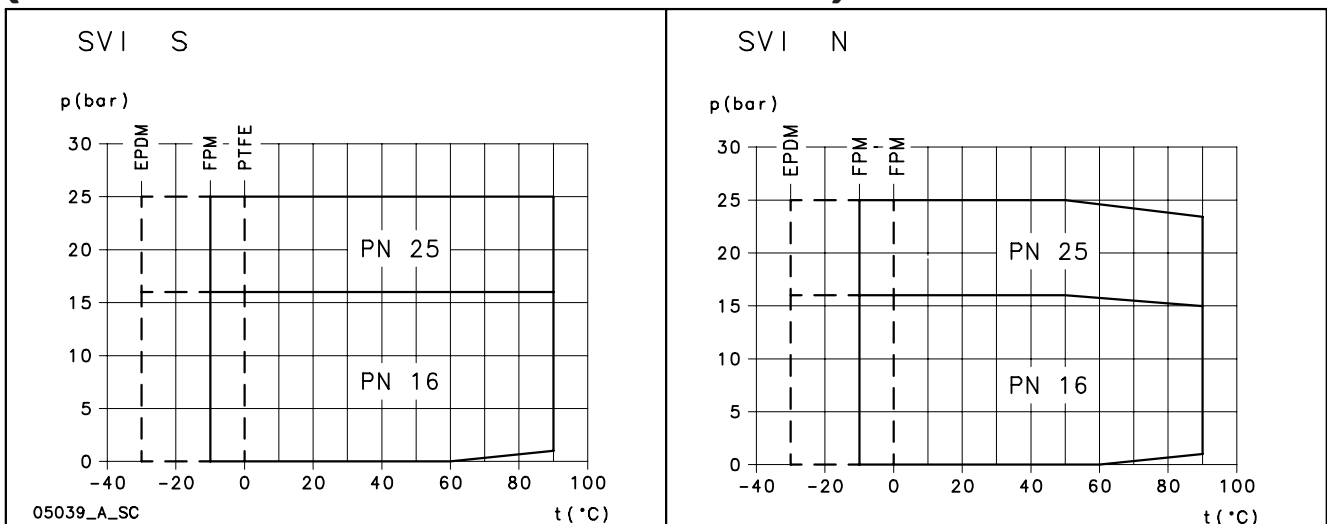

MOTORS FOR SVI SERIES

- **Standard supplied IE2 three-phase surface motors $\geq 0,75$ kW are compliant with Regulation (EC) no. 640/2009 and IEC 60034-30.**
- Short-circuit squirrel-cage motor (TEFC), enclosed construction with external ventilation.
- IP55 protection.
- Class 155 (F) insulation.
- Performance according to EN 60034-1.
- Standard voltage.
- Cable gland with standard passage dimensions according to EN 50262 (metric thread).
- **Single-phase** version: 220-240 V 50 Hz (on request).
- **Three-phase** version 220-240/380-415 V 50 Hz for power up to 3 kW.
380-415/660-690 V 50 Hz for power above 3 kW.
Overload protection to be provided by the user.

**SVI (E, EN) SERIES
THREE-PHASE MOTORS AT 50 Hz, 2 POLES**

P _N kW	Efficiency η_N																			Year of manufacture
	%																			
	Δ 220 V Y 380 V			Δ 230 V Y 400 V			Δ 240 V Y 415 V			Δ 380 V Y 660 V			Δ 400 V Y 690 V			Δ 415 V			IE	
	4/4	3/4	2/4	4/4	3/4	2/4	4/4	3/4	2/4	4/4	3/4	2/4	4/4	3/4	2/4	4/4	3/4	2/4		
0,3	-	-	-	-	-	-	-	-	-	-	-	-	-	-	-	-	-	-	-	-
0,45	-	-	-	-	-	-	-	-	-	-	-	-	-	-	-	-	-	-	-	-
0,55	-	-	-	-	-	-	-	-	-	-	-	-	-	-	-	-	-	-	-	-
0,75	77,4	77,4	74,0	77,4	77,4	74,0	77,4	77,4	74,0	77,4	77,4	74,0	77,4	77,4	74,0	77,4	77,4	74,0	77,4	74,0
0,9	80,1	80,1	78,9	80,1	80,1	78,9	80,1	80,1	78,9	80,1	80,1	78,9	80,1	80,1	78,9	80,1	80,1	78,9	80,1	78,9

P _N kW	Manufacturer		IEC SIZE	Construction Design	N. of Poles	f _N Hz	Data for 400 V / 50 Hz Voltage				
	Lowara srl Unipersonale Reg. No. 341820260 Montecchio Maggiore Vicenza - Italia						cos ϕ	I _s / I _N	T _N Nm	T _s /T _N	T _m /T _n
	Model										
0,3	SM63SE/303		63	SPECIAL	2	50	0,72	4,05	1,05	3,29	2,63
0,45	SM65SE/304		63				0,66	4,32	1,38	4,14	3,13
0,55	SM63SE/305		63				0,71	4,41	1,73	3,70	2,62
0,75	SM80SE/307		80				0,79	8,70	2,47	4,71	4,09
0,9	SM80SE/311		80				0,82	8,98	3,63	4,62	4,00

P _N kW	Voltage U _N										n _N min ⁻¹	See note.	Operating conditions **		
	V												Altitude Above Sea Level (m)	T. amb min/max °C	ATEX
	Δ			Y			Δ			Y					
	220 V	230 V	240 V	380 V	400 V	415 V	380 V	400 V	415 V	660 V	690 V				
	I _N (A)														
0,3	1,65	1,70	1,78	0,95	0,98	1,03	-	-	-	-	-	2680 ÷ 2745	≤ 1000	-15 / 40	No
0,45	2,20	2,34	2,51	1,27	1,35	1,45	-	-	-	-	-	2740 ÷ 2790			
0,55	2,53	2,63	2,81	1,46	1,52	1,62	-	-	-	-	-	2715 ÷ 2770			
0,75	3,10	3,05	3,03	1,79	1,76	1,75	1,78	1,76	1,74	1,03	1,01	2885 ÷ 2905			
0,9	4,17	4,09	4,07	2,41	2,36	2,35	2,40	2,36	2,34	1,39	1,36	2880 ÷ 2900			

Note: Observe the regulations and codes locally in force regarding sorted waste disposal.

svi-e-ie2-mott-2p50-en_a_te

** Operating conditions to be referred to motor only. About electric pump, refer to limits in user's manual.



ITT

Lowara

SVI (E, EN) SERIES THREE-PHASE MOTORS AT 50 Hz, 2 POLES (up to 22 kW)

P _N kW	Efficiency η_N %																		IE	Year of manufacture				
	Δ 220 V Y 380 V			Δ 230 V Y 400 V			Δ 240 V Y 415 V			Δ 380 V Y 660 V			Δ 400 V Y 690 V			Δ 415 V								
	4/4	3/4	2/4	4/4	3/4	2/4	4/4	3/4	2/4	4/4	3/4	2/4	4/4	3/4	2/4	4/4	3/4	2/4						
0,37	-	-	-	-	-	-	-	-	-	-	-	-	-	-	-	-	-	-	-	-	-	-	-	-
0,55	-	-	-	-	-	-	-	-	-	-	-	-	-	-	-	-	-	-	-	-	-	-	-	-
0,75	77,4	77,4	74,0	77,4	77,4	74,0	77,4	77,4	74,0	77,4	77,4	74,0	77,4	77,4	74,0	77,4	77,4	74,0	77,4	77,4	74,0	77,4	77,4	74,0
1,1	80,1	80,1	78,9	80,1	80,1	78,9	80,1	80,1	78,9	80,1	80,1	78,9	80,1	80,1	78,9	80,1	80,1	78,9	80,1	80,1	78,9	80,1	80,1	78,9
1,5	82,6	83,7	81,8	82,6	83,7	81,8	82,6	83,7	81,8	82,6	83,7	82,7	83,4	83,9	82,2	83,8	83,9	81,8	82,6	83,7	81,8	82,6	83,7	81,8
2,2	83,7	84,6	82,9	83,7	84,6	82,9	83,7	84,6	82,9	83,7	84,6	83,6	84,6	84,9	83,3	84,9	84,9	82,9	83,7	84,6	82,9	83,7	84,6	82,9
3	86,1	87,0	85,6	86,1	87,0	85,6	86,1	87,0	85,6	86,1	87,4	87,1	86,6	87,4	86,5	86,7	87,0	85,6	86,1	87,0	85,6	86,1	87,4	87,1
4	86,3	86,3	86,3	86,3	86,3	86,3	86,3	86,3	86,3	86,3	86,3	86,3	86,3	86,3	86,3	86,3	86,3	86,3	86,3	86,3	86,3	86,3	86,3	86,3
5,5	87,6	87,6	87,6	87,6	87,6	87,6	87,6	87,6	87,6	87,6	87,6	87,6	87,6	87,6	87,6	87,6	87,6	87,6	87,6	87,6	87,6	87,6	87,6	87,6
7,5	88,6	88,1	88,1	88,6	88,1	88,1	88,6	88,1	88,1	88,6	88,1	88,1	88,6	88,1	88,1	88,6	88,1	88,6	88,1	88,6	88,1	88,6	88,1	88,1
11	90,3	91,1	90,3	90,3	91,1	90,3	90,3	91,1	90,3	90,3	91,1	90,3	90,8	91,1	90,3	91,0	91,1	90,3	90,3	91,0	91,1	90,3	90,3	90,3
15	90,3	90,3	90,3	90,3	90,3	90,3	90,3	90,3	90,3	90,3	90,3	90,3	90,3	90,3	90,3	90,3	90,3	90,3	90,3	90,3	90,3	90,3	90,3	90,3
18,5	91,2	91,2	91,2	91,2	91,2	91,2	91,2	91,2	91,2	91,2	91,2	91,2	91,2	91,2	91,2	91,2	91,2	91,2	91,2	91,2	91,2	91,2	91,2	91,2
22	91,3	91,3	91,3	91,3	91,3	91,3	91,3	91,3	91,3	91,3	91,3	91,3	91,3	91,3	91,3	91,3	91,3	91,3	91,3	91,3	91,3	91,3	91,3	91,3

P _N kW	Manufacturer		IEC SIZE*	Construction Design	N. of Poles	f _N Hz	Data for 400 V / 50 Hz Voltage				
	Lowara srl Unipersonale Reg. No. 341820260 Montecchio Maggiore Vicenza - Italia						cos ϕ	I _s / I _N	T _N Nm	Ts/T _N	Tm/Tn
	Model										
0,37	SM071RB14/304		71R	V18/B14	2	50	0,66	4,32	1,38	4,14	3,13
0,55	SM071B14/305		71				0,74	5,97	1,85	3,74	3,56
0,75	SM080B14/307HE		80				0,79	8,70	2,47	4,71	4,09
1,1	SM080B14/311HE		80				0,82	8,98	3,63	4,62	4,00
1,5	PLM090B14/315		90				0,86	7,86	4,96	3,34	3,27
2,2	PLM090B14/322		90				0,80	8,63	7,25	3,74	3,71
3	PLM100RB14/330		100R				0,82	8,39	9,96	3,50	3,32
4	PLM112RB14/340		112R				0,85	9,52	13,1	3,04	4,40
5,5	PLM132RB5/355		132R				0,87	10,3	18,1	4,43	5,80
7,5	PLM132B5/375		132				0,87	9,21	24,5	3,26	4,55
11	PLM160RB5/3110		160R				0,87	9,72	36,0	3,46	4,56
15	PLM160B5/3150		160				0,91	8,45	48,6	2,26	3,81
18,5	PLM160B5/3185		160				0,88	9,75	59,8	2,82	4,53
22	PLM180RB5/3220		180R				0,89	9,50	71,1	2,74	4,26

P _N kW	Voltage U _N V											η_N min ⁻¹	Observe the regulations and codes locally in force regarding sorted waste disposal.	Operating conditions **		
	Δ			Y			Δ			Y				Altitude Above Sea Level (m)	T. amb min/max °C	ATEX
	220 V	230 V	240 V	380 V	400 V	415 V	380 V	400 V	415 V	660 V	690 V					
0,37	2,20	2,34	2,51	1,27	1,35	1,45	-	-	-	-	-	2740 ÷ 2790	≤ 1000	-15 / 40	No	
0,55	2,56	2,56	2,62	1,48	1,48	1,51	-	-	-	-	-	2825 ÷ 2850				
0,75	3,10	3,05	3,03	1,79	1,76	1,75	1,78	1,76	1,74	1,03	1,01	2885 ÷ 2905				
1,1	4,17	4,09	4,07	2,41	2,36	2,35	2,40	2,36	2,34	1,39	1,36	2880 ÷ 2900				
1,5	5,53	5,23	5,13	3,19	3,02	2,96	3,19	3,03	2,96	1,84	1,75	2865 ÷ 2895				
2,2	8,05	8,04	8,09	4,65	4,64	4,67	4,62	4,61	4,63	2,67	2,66	2885 ÷ 2900				
3	10,8	10,6	10,6	6,23	6,14	6,12	6,18	6,10	6,06	3,57	3,52	2850 ÷ 2885				
4	13,6	13,5	13,5	7,88	7,77	7,79	7,80	7,63	7,65	4,51	4,41	2895 ÷ 2920				
5,5	18,3	18,0	17,9	10,6	10,4	10,3	10,6	10,4	10,5	6,14	6,02	2885 ÷ 2905				
7,5	25,4	24,8	24,4	14,7	14,3	14,1	14,5	14,0	13,9	8,35	8,11	2920 ÷ 2935				
11	36,0	35,1	34,7	20,8	20,3	20,0	20,8	20,3	20,1	12,0	11,7	2910 ÷ 2925				
15	47,2	45,3	44,0	27,2	26,2	25,4	27,2	26,0	25,3	15,7	15,0	2940 ÷ 2950				
18,5	58,3	56,9	55,9	33,7	32,9	32,3	34,1	33,2	32,8	19,7	19,1	2945 ÷ 2955				
22	68,3	66,2	64,3	39,4	38,2	37,1	40,0	38,6	37,8	23,1	22,3	2945 ÷ 2955				

* R = Reduced size of motor casing as compared to shaft extension and flange.

svi-s-ie2-mott-2p50-en_a_te

** Operating conditions to be referred to motor only. About electric pump, refer to limits in user's manual.

**SVI (S, N) SERIES
THREE-PHASE MOTORS AT 50 Hz, 2 POLES (from 30 kW)**

P _N kW	Efficiency η_N %									IE	Year of manufacture
	Δ 380 V Y 660 V			Δ 400 V Y 690 V			Δ 415 V				
	4/4	3/4	2/4	4/4	3/4	2/4	4/4	3/4	2/4		
30	92,6	92,9	92,7	92,5	93,0	92,9	93,0	93,0	92,3	2	By June 2011

P _N kW	Manufacturer		IEC SIZE	Construction Design	N. of Poles	f _N Hz	Data for 400 V / 50 Hz Voltage						
	WEG Equipamentos Eletricos S.A. Reg. No. 07.175.725/0010-50 Jaragua do Sul - SC (Brazil)						cos ϕ	I _s / I _N	T _N Nm	T _s /T _N	T _m /T _n		
	Model												
30	W22 200L2-B5 30kW		200	V1/B5	2	50	0,87	6,50	97,0	2,40	2,70		

P _N kW	Voltage U _N V					n _N min ⁻¹	See note.	Operating conditions **		
	Δ			Y				Altitude Above Sea Level (m)	T. amb min/max °C	ATEX
	380 V	400 V	415 V	660 V	690 V					
30	I _N (A)					2950 ÷ 2960		≤ 1000	-15 / 40	No
	55,9	53,6	52,2	32,2	31,1					

** Operating conditions to be referred to motor only. About electric pump, refer to limits in user's manual.

svi-s-ie2-mott30-2p50-en_a_te

Note: Observe the regulations and codes locally in force regarding sorted waste disposal.

MOTOR NOISE

The tables below show the mean sound pressure levels (Lp) measured at 1 meter's distance in a free field according to the A curve (ISO 1680 standard).

The noise values are measured with idling 50 Hz motor with a tolerance of 3 dB (A).

**SVI (E, EN) THREE-PHASE 50 Hz, SVI (S, N) THREE-PHASE 50 Hz,
2 POLES MOTORS**

POWER kW	MOTOR TYPE IEC SIZE	NOISE LpA dB
0,37	63	<70
0,45	63	<70
0,55	63	<70
0,75	71	<70
0,9	71	<70

POWER kW	MOTOR TYPE IEC SIZE*	RUMOROSITA' LpA dB
0,37	71R	<70
0,55	71	<70
0,75	80R	<70
1,1	80	<70
1,5	90R	<70
2,2	90R	<70
3	100R	<70
4	112R	<70
5,5	132R	<70
7,5	132	71
11	160R	73
15	160	71
18,5	160	73
22	180R	70
30	200	72

*R=Reduced motor casing size with respect to shaft extension and related flange.

sv_mott-en_b_tr



ITT

Lowara

AVAILABLE VOLTAGES MOTORS FOR SVI SERIES (up to 22 kW)

P _N kW	THREE-PHASE - 2 POLES																
	50 Hz							60 Hz							50/60 Hz		
	3 x 220-230-240/380-400-415	3 x 380-400-415/660-690	3 x 200-208/346-360	3 x 255-265/440-460	3 x 290-300/500-525	3 x 440-460/-	3 x 500-525/-	3 x 220-230/380-400	3 x 255-265-277/440-460-480	3 x 380-400/660-690	3 x 440-460-480/-	3 x 110-115/190-200	3 x 200-208/346-360	3 x 330-346/575-600	3 x 575/-	3 x 230/400 50 Hz	3 x 265/460 60 Hz
0,3	s	o	o	o	o	o	o	s	o	o	o	o	o	o	o	o	o
0,37	s	o	o	o	o	o	o	s	o	o	o	o	o	o	o	o	o
0,4	s	o	o	o	o	o	o	s	o	o	o	o	o	o	o	o	o
0,5	s	o	o	o	o	o	o	s	o	o	o	o	o	o	o	o	o
0,55	s	o	o	o	o	o	o	s	o	o	o	o	o	o	o	o	o
0,75	s	o	o	o	o	o	o	s	o	o	o	o	o	o	o	o	o
0,95	s	o	o	o	o	o	o	s	o	o	o	o	o	o	o	o	o
1,1	s	o	o	o	o	o	o	s	o	o	o	o	o	o	o	o	o
1,5	s	o	o	o	o	o	o	s	o	o	o	o	o	o	o	o	o
2,2	s	o	o	o	o	o	o	s	o	o	o	o	o	o	o	o	o
3	s	o	o	o	o	o	o	s	o	o	o	o	o	o	o	o	o
4	o	s	o	o	o	o	o	s	o	o	o	o	o	o	o	o	o
5,5	o	s	o	o	o	o	o	s	o	o	o	o	o	o	o	o	o
7,5	o	s	o	o	o	o	o	s	o	o	o	o	o	o	o	o	o
11	o	s	o	o	o	o	o	s	o	o	o	o	o	o	o	o	o
15	o	s	o	o	o	o	o	s	o	o	o	o	o	o	o	o	o
18,5	o	s	o	o	o	o	o	s	o	o	o	o	o	o	o	o	o
22	o	s	o	o	o	o	o	s	o	o	o	o	o	o	o	o	o

s = Standard voltage

o = Optional voltage

- = Not available

svi-volt-low-a-en_a_te

MOTORS FOR SVI SERIES (≥ 30 kW)

P _N kW	THREE-PHASE - 2 POLES																		
	50 Hz							60 Hz							50/60 Hz				
	3 x 220-230-240/380-400-415	3 x 380-400-415/660-690	3 x 110/190	3 x 200-208/346-360	3 x 255-265/440-460	3 x 290-300/500-525	3 x 440-460/-	3 x 500-525/-	3 x 230/380	3 x 380-400/660-690	3 x 440-480/-	3 x 440-460/-	3 x 110-115/190-200	3 x 200-208/346-360	3 x 255-265-277/440-460-480	3 x 330-346/575-600	3 x 575/-	3 x 230/400 50 Hz	3 x 265/460 60 Hz
30	o	s	o	o	o	o	o	o	s	o	o	o	o	o	o	o	o	o	o

s = Standard voltage

o = Optional voltage

- = Not available

svi-volt-weg-en_a_te



SVI SERIES HYDRAULIC PERFORMANCE RANGE AT 50 Hz

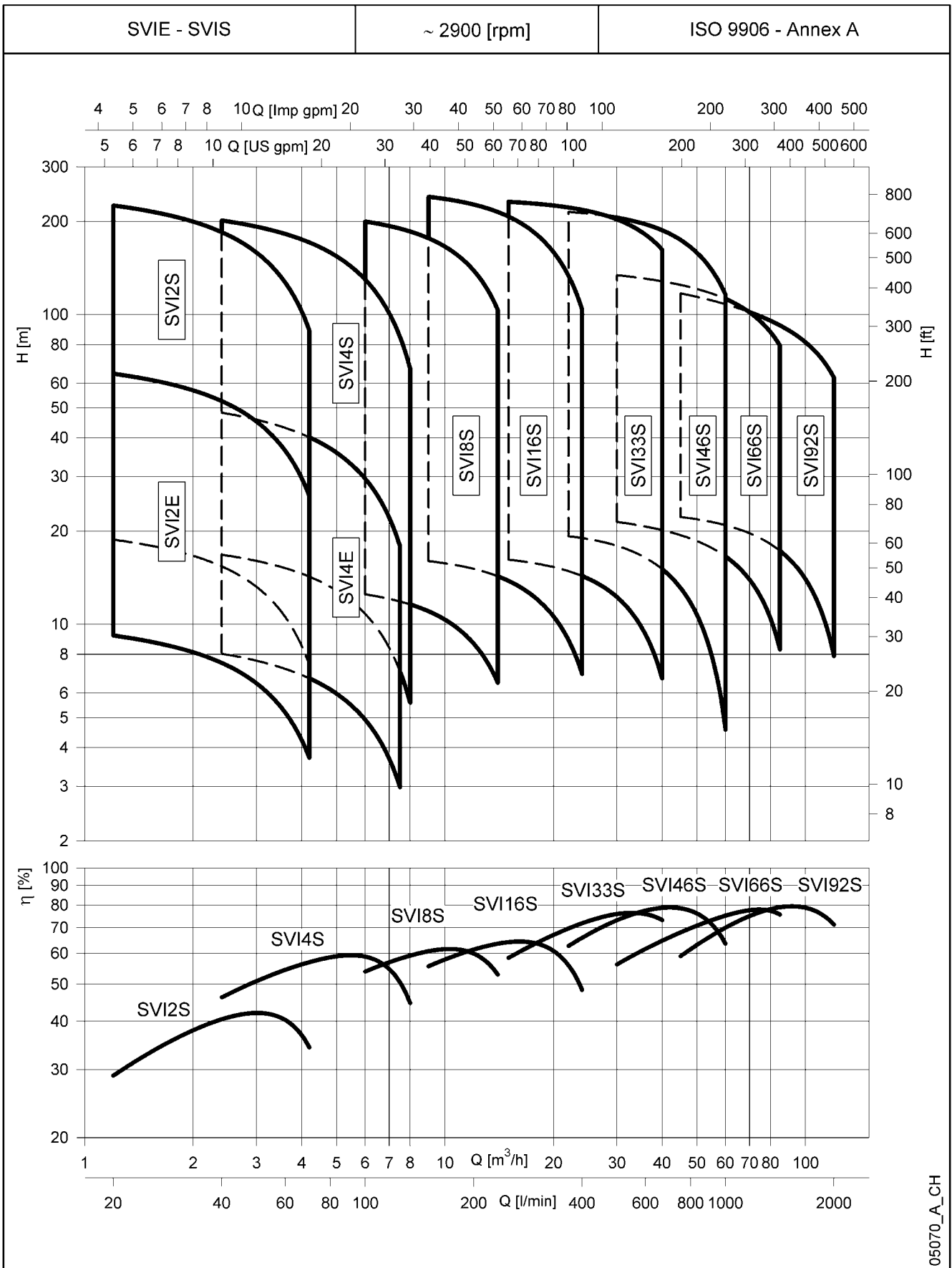



ITT

Lowara

SVI 2, 4 SERIES

TABLE OF HYDRAULIC PERFORMANCES AT 50 Hz, 2 POLES

PUMP TYPE	RATED POWER		Q = DELIVERY											
			V _{min} 0	20	30	40	50	60	70	80	90	100	110	120
	kW	HP	m ³ /h 0	1,2	1,8	2,4	3	3,6	4,2	4,8	5,4	6	6,6	7,2
H = TOTAL HEAD METRES COLUMN OF WATER														
SVI 201E	0,37	0,5	10,6	9,2	8,4	7,5	6,5	5,2	3,7					
SVI 202E	0,37	0,5	21,2	18,4	16,8	15,0	12,9	10,4	7,4					
SVI 203E	0,45	0,6	31,8	27,6	25,3	22,5	19,4	15,6	11,1					
SVI 204E	0,55	0,75	42,4	36,9	33,7	30,1	25,8	20,8	14,8					
SVI 205E	0,75	1	53,0	46,1	42,1	37,6	32,3	26,0	18,6					
SVI 206E	0,75	1	63,7	55,3	50,5	45,1	38,7	31,2	22,3					
SVI 207E	0,9	1,2	74,3	64,5	58,9	52,6	45,2	36,4	26,0					
SVI 401E	0,37	0,5	9,5			8,0	7,6	7,2	6,7	6,2	5,6	4,9	4,2	3,4
SVI 402E	0,37	0,5	19,0			16,1	15,3	14,4	13,4	12,3	11,2	9,9	8,4	6,8
SVI 403E	0,45	0,6	28,5			24,1	22,9	21,5	20,1	18,5	16,7	14,8	12,6	10,2
SVI 404E	0,55	0,75	38,0			32,1	30,5	28,7	26,8	24,7	22,3	19,7	16,8	13,6
SVI 405E	0,75	1	47,5			40,2	38,1	35,9	33,5	30,8	27,9	24,6	21,0	17,1
SVI 406E	0,9	1,2	57,0			48,2	45,8	43,1	40,2	37,0	33,5	29,6	25,3	20,5
SVI 202S	0,37	0,5	21,4	18,8	17,2	15,4	13,2	10,6	7,4					
SVI 203S	0,37	0,5	32,1	28,1	25,8	23,1	19,8	15,9	11,1					
SVI 204S	0,55	0,75	42,8	37,5	34,4	30,8	26,4	21,2	14,8					
SVI 205S	0,75	1	53,5	46,9	43,0	38,5	33,0	26,5	18,6					
SVI 206S	0,75	1	64,2	56,3	51,6	46,2	39,6	31,7	22,3					
SVI 207S	1,1	1,5	74,9	65,6	60,2	53,9	46,2	37,0	26,0					
SVI 208S	1,1	1,5	85,6	75,0	68,8	61,5	52,8	42,3	29,7					
SVI 209S	1,1	1,5	96,3	84,4	77,4	69,2	59,4	47,6	33,4					
SVI 211S	1,5	2	117,7	103,2	94,6	84,6	72,6	58,2	40,8					
SVI 212S	1,5	2	128,4	112,5	103,2	92,3	79,2	63,5	44,5					
SVI 214S	2,2	3	149,8	131,3	120,4	107,7	92,5	74,1	52,0					
SVI 216S	2,2	3	171,2	150,1	137,7	123,1	105,7	84,7	59,4					
SVI 218S	2,2	3	192,6	168,8	154,9	138,5	118,9	95,2	66,8					
SVI 220S	3	4	214,0	187,6	172,1	153,9	132,1	105,8	74,2					
SVI 222S	3	4	235,4	206,3	189,3	169,2	145,3	116,4	81,7					
SVI 224S	3	4	256,8	225,1	206,5	184,6	158,5	127,0	89,1					
SVI 402S	0,37	0,5	19,3			16,8	16,0	15,2	14,3	13,2	12,1	10,8	9,4	7,9
SVI 403S	0,55	0,75	28,9			25,2	24,0	22,8	21,4	19,8	18,1	16,2	14,1	11,8
SVI 404S	0,75	1	38,5			33,6	32,0	30,4	28,5	26,5	24,2	21,6	18,9	15,8
SVI 405S	1,1	1,5	48,2			42,0	40,1	38,0	35,6	33,1	30,2	27,1	23,6	19,7
SVI 406S	1,1	1,5	57,8			50,4	48,1	45,6	42,8	39,7	36,3	32,5	28,3	23,7
SVI 407S	1,1	1,5	67,5			58,7	56,1	53,1	49,9	46,3	42,3	37,9	33,0	27,6
SVI 408S	1,5	2	77,1			67,1	64,1	60,7	57,0	52,9	48,3	43,3	37,7	31,5
SVI 409S	1,5	2	86,7			75,5	72,1	68,3	64,2	59,5	54,4	48,7	42,4	35,5
SVI 411S	2,2	3	106,0			92,3	88,1	83,5	78,4	72,8	66,5	59,5	51,9	43,4
SVI 413S	2,2	3	125,3			109,1	104,2	98,7	92,7	86,0	78,6	70,4	61,3	51,3
SVI 414S	3	4	134,9			117,5	112,2	106,3	99,8	92,6	84,6	75,8	66,0	55,2
SVI 416S	3	4	154,2			134,3	128,2	121,5	114,1	105,8	96,7	86,6	75,4	63,1
SVI 418S	3	4	173,5			151,1	144,2	136,7	128,3	119,0	108,8	97,4	84,8	71,0
SVI 420S	4	5,5	192,7			167,9	160,2	151,8	142,6	132,3	120,9	108,2	94,3	78,9
SVI 422S	4	5,5	212,0			184,6	176,3	167,0	156,8	145,5	133,0	119,1	103,7	86,7
SVI 424S	4	5,5	231,3			201,4	192,3	182,2	171,1	158,7	145,0	129,9	113,1	94,6

Performances in compliance with ISO 9906 - Annex A.

svi2-4-2p50-en_a_th



ITT

Lowara

SVI 8, 16 SERIES

TABLE OF HYDRAULIC PERFORMANCES AT 50 Hz, 2 POLES

PUMP TYPE	RATED POWER		Q = DELIVERY											
			V _{min 0}	100	125	150	175	200	233	250	275	300	350	400
	kW	HP	m ³ /h 0	6	7,5	9	10,5	12	14	15	16,5	18	21	24
H = TOTAL HEAD METRES COLUMN OF WATER														
SVI 801S	0,75	1	14,0	12,5	11,8	11,0	10,0	8,7	6,5					
SVI 802S	1,1	1,5	28,0	25,0	23,7	22,1	20,0	17,4	13,0					
SVI 803S	1,5	2	42,0	37,5	35,5	33,1	29,9	26,0	19,4					
SVI 804S	2,2	3	56,0	50,0	47,4	44,1	39,9	34,7	25,9					
SVI 805S	2,2	3	70,0	62,4	59,2	55,1	49,9	43,4	32,4					
SVI 806S	3	4	84,0	74,9	71,1	66,2	59,9	52,1	38,9					
SVI 808S	4	5,5	112,0	99,9	94,8	88,2	79,9	69,5	51,8					
SVI 809S	4	5,5	126,0	112,4	106,6	99,2	89,8	78,1	58,3					
SVI 811S	5,5	7,5	154,0	137,4	130,3	121,3	109,8	95,5	71,3					
SVI 812S	5,5	7,5	168,0	149,9	142,2	132,3	119,8	104,2	77,8					
SVI 814S	7,5	10	196,0	174,9	165,9	154,4	139,8	121,5	90,7					
SVI 816S	7,5	10	224,0	199,8	189,6	176,4	159,7	138,9	103,7					
SVI 1601S	1,1	1,5	16,9			16,0	15,6	15,1	14,3	13,8	13,0	12,1	9,8	6,9
SVI 1602S	2,2	3	33,7			32,0	31,2	30,2	28,6	27,6	26,0	24,1	19,6	13,9
SVI 1603S	3	4	50,6			48,0	46,8	45,3	42,9	41,5	39,0	36,2	29,4	20,8
SVI 1604S	4	5,5	67,5			64,0	62,4	60,4	57,2	55,3	52,0	48,3	39,1	27,7
SVI 1605S	5,5	7,5	84,3			80,0	78,0	75,6	71,5	69,1	65,0	60,3	48,9	34,6
SVI 1606S	5,5	7,5	101,2			96,0	93,6	90,7	85,8	82,9	78,0	72,4	58,7	41,6
SVI 1607S	7,5	10	118,1			112,0	109,2	105,8	100,1	96,7	91,0	84,5	68,5	48,5
SVI 1608S	7,5	10	134,9			128,0	124,8	120,9	114,4	110,6	104,0	96,5	78,3	55,4
SVI 1610S	11	15	168,7			160,0	156,0	151,1	143,0	138,2	130,0	120,7	97,9	69,3
SVI 1612S	11	15	202,4			192,0	187,2	181,3	171,6	165,8	156,1	144,8	117,4	83,1
SVI 1614S	15	20	236,1			224,0	218,4	211,6	200,2	193,5	182,1	168,9	137,0	97,0
SVI 1615S	15	20	253,0			240,0	234,1	226,7	214,5	207,3	195,1	181,0	146,8	103,9

Performances in compliance with ISO 9906 - Annex A.

svi8-16-2p50-en_a_th



ITT

Lowara

SVI 33, 46 SERIES

TABLE OF HYDRAULIC PERFORMANCES AT 50 Hz, 2 POLES

PUMP TYPE	RATED POWER		Q = DELIVERY											
			V _{min} 0	250	300	366,7	400	500	600	666,7	700	800	900	1000
	kW	HP	m ³ /h 0	15	18	22	24	30	36	40	42	48	54	60
H = TOTAL HEAD METRES COLUMN OF WATER														
SVI 3301/1S	2,2	3	17,4	16,2	15,7	14,9	14,3	12,2	9,3	6,7				
SVI 3301S	3	4	23,8	21,7	21,2	20,3	19,8	17,8	15,0	12,7				
SVI 3302/2S	4	5,5	35,1	34,1	33,3	31,8	30,8	26,9	21,4	16,6				
SVI 3302/1S	4	5,5	40,8	38,8	37,9	36,3	35,4	31,7	26,6	22,3				
SVI 3303/2S	5,5	7,5	57,7	55,2	53,8	51,4	49,9	44,1	36,2	29,6				
SVI 3303S	7,5	10	71,5	67,4	66,2	64,0	62,7	57,7	50,7	44,6				
SVI 3304S	11	15	95,9	91,1	89,7	87,2	85,7	79,6	70,8	63,1				
SVI 3305/1S	11	15	112,7	107,2	105,3	101,9	99,8	91,7	80,0	70,0				
SVI 3306/2S	15	20	131,2	126,9	124,6	120,3	117,7	107,5	93,2	81,2				
SVI 3307/2S	15	20	156,0	149,9	147,3	142,7	139,8	128,4	112,2	98,2				
SVI 3307S	18,5	25	170,3	162,8	160,2	155,7	153,0	142,2	126,7	113,2				
SVI 3308/1S	18,5	25	187,4	179,5	176,5	171,3	168,1	155,5	137,4	121,7				
SVI 3309/1S	22	30	210,2	201,2	197,8	191,8	188,2	173,8	153,4	135,9				
SVI 3310/2S	22	30	226,4	217,2	213,4	206,8	202,6	186,4	163,5	143,9				
SVI 3310S	30	40	241,8	231,3	227,8	221,7	217,9	202,9	181,1	162,1				
SVI 4601/1S	3	4	19,5			19,2	19,0	17,9	16,4	15,1	14,4	11,7	8,5	4,6
SVI 4601S	4	5,5	27,2			24,0	23,7	22,5	21,1	19,9	19,3	17,1	14,3	10,8
SVI 4602/2S	5,5	7,5	38,8			39,8	39,4	37,8	35,2	32,9	31,6	26,9	21,1	13,9
SVI 4602S	7,5	10	52,6			48,5	48,0	46,1	43,7	41,7	40,6	36,5	31,4	25,1
SVI 4603S	11	15	80,8			74,3	73,5	70,9	67,4	64,6	62,9	57,1	49,8	40,7
SVI 4604/2S	15	20	92,4			90,7	89,9	86,9	82,5	78,6	76,3	68,3	58,2	45,6
SVI 4605S	18,5	25	134,5			125,1	124,0	120,0	114,7	110,2	107,6	98,3	86,4	71,5
SVI 4606S	22	30	161,0			149,8	148,5	143,8	137,4	132,0	128,9	117,8	103,7	86,0
SVI 4607/2S	30	40	171,3			164,9	163,6	158,3	150,8	144,3	140,6	127,1	109,9	88,6
SVI 4608/2S	30	40	198,2			190,0	188,4	182,4	173,8	166,4	162,2	146,9	127,3	103,1
SVI 4609/2S	30	40	224,8			214,5	212,6	205,6	195,7	187,3	182,5	165,2	143,2	116,0

Performances in compliance with ISO 9906 - Annex A.

svi33-46-2p50-en_a_th



ITT

Lowara

SVI 66, 92 SERIES

TABLE OF HYDRAULIC PERFORMANCES AT 50 Hz, 2 POLES

PUMP TYPE	RATED POWER		Q = DELIVERY											
			l/min 0	500	600	750	900	1000	1100	1200	1416,7	1600	1800	2000
	kW	HP	m ³ /h 0	30	36	45	54	60	66	72	85	96	108	120
H = TOTAL HEAD METRES COLUMN OF WATER														
SVI 6601/1S	4	5,5	23,8	21,4	20,7	19,4	17,8	16,6	15,1	13,3	8,3			
SVI 6601S	5,5	7,5	29,2	25,8	24,8	23,3	21,8	20,7	19,4	17,9	13,4			
SVI 6602/2S	7,5	10	47,5	42,6	41,2	38,6	35,5	32,9	30,0	26,4	16,4			
SVI 6602S	11	15	60,4	55,7	54,4	52,0	49,3	47,1	44,7	42,0	34,6			
SVI 6603/2S	15	20	78,4	71,6	69,6	65,9	61,5	57,9	53,8	49,0	35,3			
SVI 6603S	18,5	25	91,4	84,7	82,7	79,3	75,2	72,0	68,5	64,4	53,5			
SVI 6604/1S	22	30	115,2	105,9	103,1	98,5	92,9	88,6	83,6	77,8	61,7			
SVI 6605/1S	30	40	145,6	134,0	130,5	124,7	117,8	112,4	106,3	99,2	79,4			
SVI 9201/1S	5,5	7,5	24,5			22,2	21,5	20,9	20,2	19,4	17,3	15,0	11,8	7,9
SVI 9201S	7,5	10	33,5			28,7	27,2	26,2	25,3	24,3	22,2	20,2	17,6	14,3
SVI 9202/2S	11	15	49,4			45,1	43,7	42,5	41,2	39,6	35,5	30,9	24,6	16,8
SVI 9202S	15	20	67,8			58,2	55,3	53,4	51,4	49,5	45,3	41,4	36,3	29,6
SVI 9203/2S	18,5	25	82,4			74,4	71,6	69,6	67,3	64,8	58,6	52,2	43,6	32,9
SVI 9203S	22	30	102,2			88,2	84,0	81,2	78,4	75,5	69,2	63,4	55,9	46,3
SVI 9204/2S	30	40	115,7			104,0	99,9	97,0	93,8	90,4	82,2	73,8	62,8	49,0
SVI 9204S	30	40	133,1			117,0	111,7	108,0	104,4	100,6	92,3	84,6	74,8	62,5

Performances in compliance with ISO 9906 - Annex A.

svi66-92-2p50-en_a_th



ITT

Lowara

SVI 2 (E, EN) SERIES DIMENSIONS AND WEIGHTS AT 50 Hz, 2 POLES

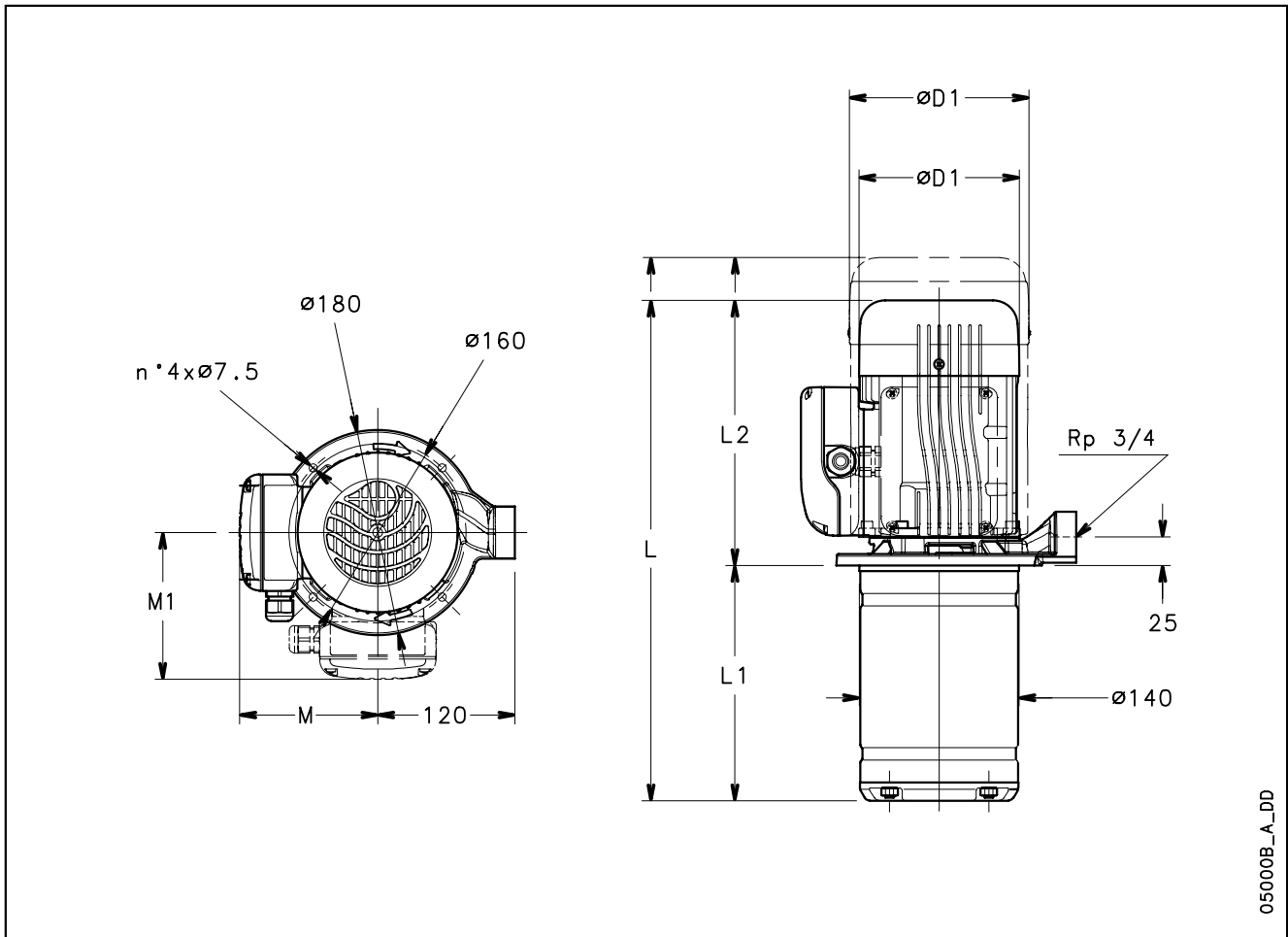

05000B_A_DD

PUMP TYPE	MOTOR		DIMENSIONS (mm)						ELECTRIC PUMP WEIGHT
	kW	SIZE	L	L1	L2	M	M1	D1	kg
SVI201/03E03T	0,37	63	324	106	218	111	-	120	8,8
SVI202/03E03T	0,37	63	324	106	218	111	-	120	8,9
SVI203/03E04T	0,45	63	324	106	218	111	-	120	9,8
SVI204/04E05T	0,55	63	349	131	218	111	-	120	10,6
SVI205/05E07T	0,75	80	433	156	276	-	129	155	16,8
SVI206/06E07T	0,75	80	458	181	276	-	129	155	17,2
SVI207/07E09T	0,9	80	483	206	276	-	129	155	18,3

svi2e-2p50-en_c_td

N. OF IMPELLERS	PUMP TYPE	MOTOR		DIMENS. L2 mm	NUMBER OF STAGES							
		kW	SIZE		3	4	5	6	7	8	10	13
					L1 Shank lengths in mm (AVAILABLE ON REQUEST)							
	SVI201/..	0,37	63	218	106	131	156	181	206	231	281	356
	SVI202/..	0,37	63	218	106	131	156	181	206	231	281	356
	SVI203/..	0,45	63	218	106	131	156	181	206	231	281	356
	SVI204/..	0,55	63	218		131	156	181	206	231	281	356
	SVI205/..	0,75	80	276			156	181	206	231	281	356
	SVI206/..	0,75	80	276				181	206	231	281	356
	SVI207/..	0,9	80	276					206	231	281	356

svi2e-en_b_tcm



ITT

Lowara

SVI 2 (E, EN) SERIES

OPERATING CHARACTERISTICS AT 50 Hz, 2 POLES, 2 POLES

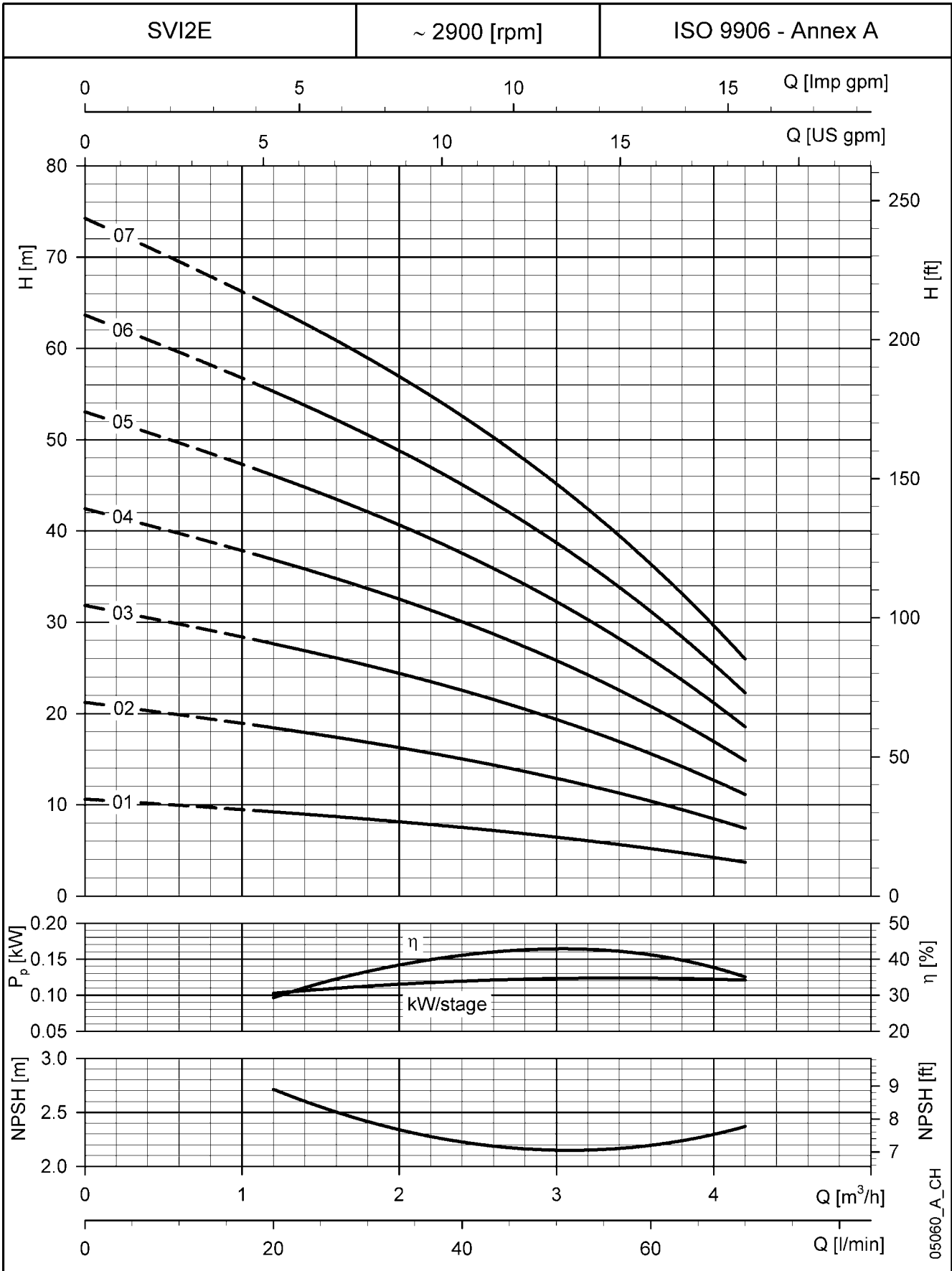

These performances are valid for liquids with density $\rho = 1.0 \text{ Kg/dm}^3$ and kinematic viscosity $\nu = 1 \text{ mm}^2/\text{sec}$.



ITT

Lowara

SVI 4 (E, EN) SERIES DIMENSIONS AND WEIGHTS AT 50 Hz, 2 POLES

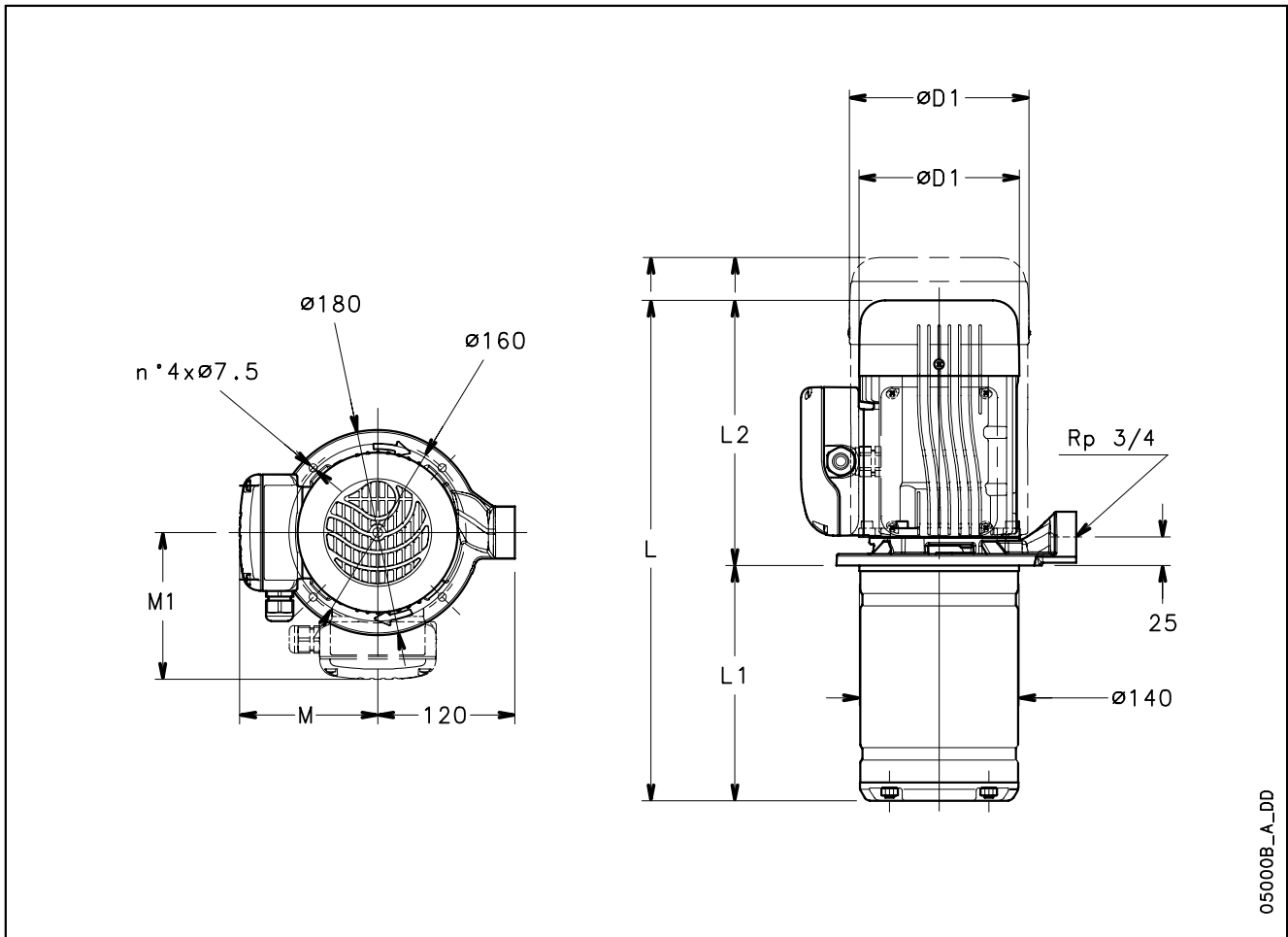

05000B_A_DD

PUMP TYPE	MOTOR		DIMENSIONS (mm)						ELECTRIC PUMP WEIGHT
	kW	SIZE	L	L1	L2	M	M1	D1	kg
SVI401/03E03T	0,37	63	324	106	218	111	-	120	8,8
SVI402/03E03T	0,37	63	324	106	218	111	-	120	8,9
SVI403/03E04T	0,45	63	324	106	218	111	-	120	9,8
SVI404/04E05T	0,55	63	349	131	218	111	-	120	10,6
SVI405/05E07T	0,75	80	433	156	276	-	129	155	16,8
SVI406/06E09T	0,9	80	458	181	276	-	129	155	17,9

svi4e-2p50-en_c_td

N. OF IMPELLERS	PUMP TYPE	MOTOR		DIMENS. L2 mm	NUMBER OF STAGES							
		kW	SIZE		3	4	5	6	7	8	10	13
					L1 Shank lengths in mm (AVAILABLE ON REQUEST)							
	SVI401/..	0,37	63	218	106	131	156	181	206	231	281	356
	SVI402/..	0,37	63	218	106	131	156	181	206	231	281	356
	SVI403/..	0,45	63	218	106	131	156	181	206	231	281	356
	SVI404/..	0,55	63	218		131	156	181	206	231	281	356
	SVI405/..	0,75	80	276			156	181	206	231	281	356
	SVI406/..	0,99	80	276				181	206	231	281	356

svi4e-en_b_tcm



ITT

Lowara

SVI 4 (E, EN) SERIES OPERATING CHARACTERISTICS AT 50 Hz, 2 POLES

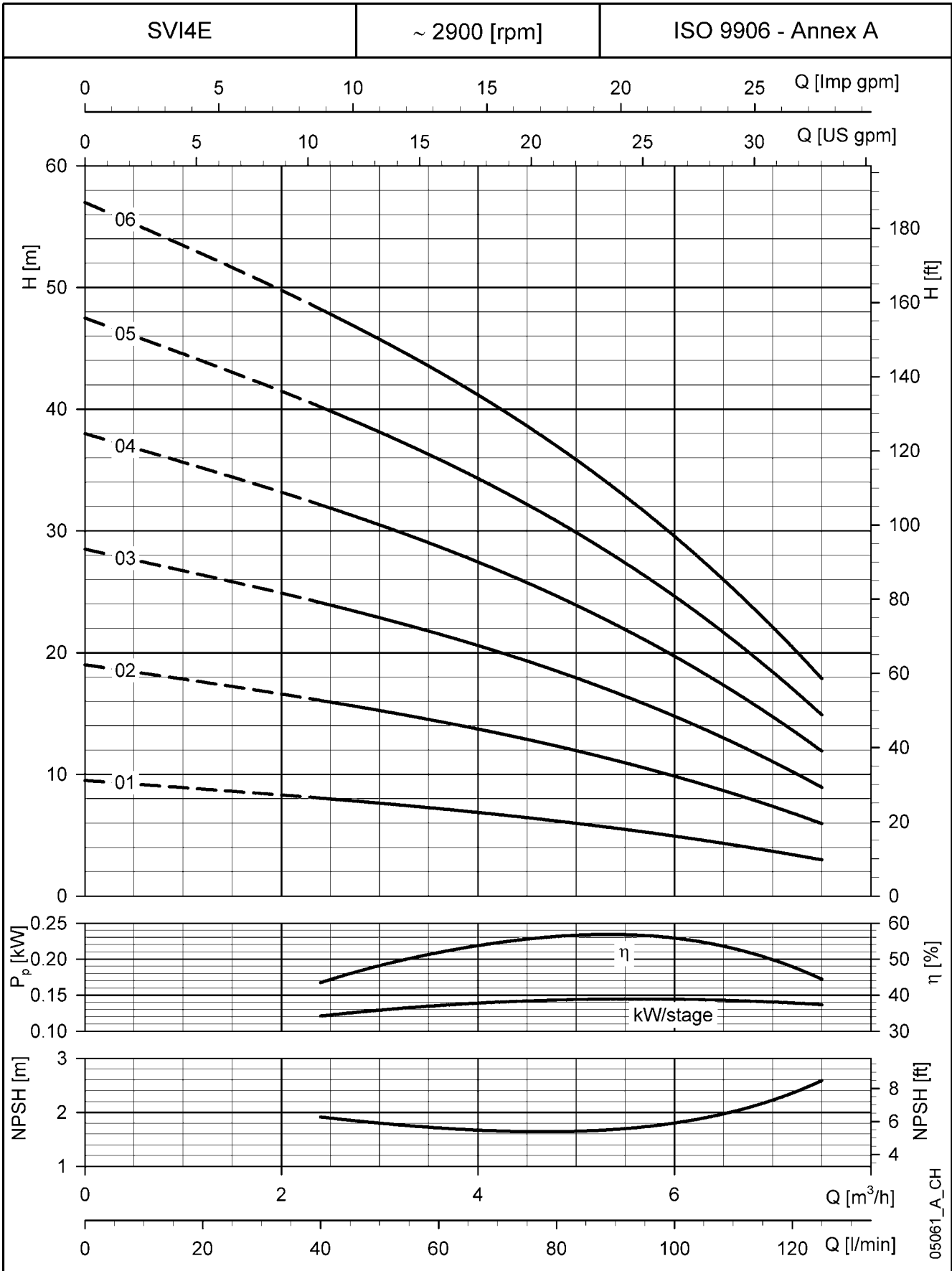

These performances are valid for liquids with density $\rho = 1.0 \text{ Kg/dm}^3$ and kinematic viscosity $\nu = 1 \text{ mm}^2/\text{sec}$.



ITT

Lowara

SVI 2 (S, N) SERIES DIMENSIONS AND WEIGHTS AT 50 Hz, 2 POLES

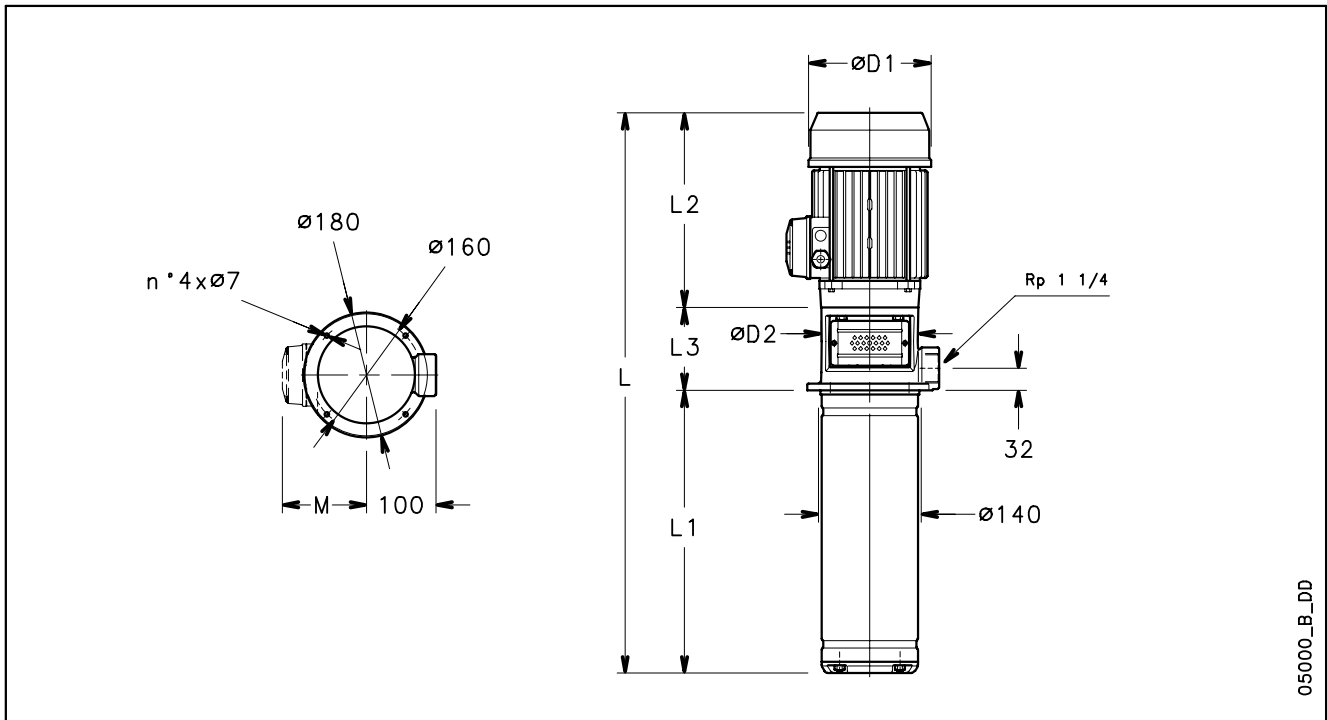

05000_B_DD

PUMP TYPE	MOTOR		DIMENSIONS (mm)							ELECTRIC PUMP WEIGHT	
	kW	SIZE	L	L1	L2	L3	M	D1	D2	kg	
SVI202/02S03T	0,37	71	416	107	209	100	111	120	105	14	
SVI203/03S03T	0,37	71	441	132	209	100	111	120	105	14	
SVI204/04S05T	0,55	71	488	157	231	100	121	140	105	15	
SVI205/05S07T	0,75	80	555	182	263	110	129	155	120	21	
SVI206/06S07T	0,75	80	580	207	263	110	129	155	120	21	
SVI207/07S11T	1,1	80	604	231	263	110	129	155	120	22	
SVI208/08S11T	1,1	80	629	256	263	110	129	155	120	22	
SVI209/09S11T	1,1	80	654	281	263	110	129	155	120	23	
SVI211/11S15T	1,5	90	749	331	298	120	134	174	140	30	
SVI212/12S15T	1,5	90	774	356	298	120	134	174	140	30	
SVI214/14S22T	2,2	90	824	406	298	120	134	174	140	32	
SVI216/16S22T	2,2	90	874	456	298	120	134	174	140	33	
SVI218/18S22T	2,2	90	924	506	298	120	134	174	140	34	
SVI220/20S30T	3	100	984	556	298	130	134	174	160	35	
SVI222/22S30T	3	100	1034	606	298	130	134	174	160	35	
SVI224/24S30T	3	100	1084	656	298	130	134	174	160	36	

svi2s-2p50-en_c_td

NUMBER OF IMPELLERS	PUMP TYPE	MOTOR		DIMENS. L2+L3 mm	NUMBER OF STAGES																	
		kW	SIZE		2	3	4	5	6	7	8	9	11	12	13	14	15	16	18	20	22	24
		L1 Shank lengths in mm (AVAILABLE ON REQUEST)																				
SVI202/..	0,37	71	309	107	132	157	182	207	231	256	281	331	356	381	406	431	456	506	556	606	656	
SVI203/..	0,37	71	309		132	157	182	207	231	256	281	331	356	381	406	431	456	506	556	606	656	
SVI204/..	0,55	71	331			157	182	207	231	256	281	331	356	381	406	431	456	506	556	606	656	
SVI205/..	0,75	80	373				182	207	231	256	281	331	356	381	406	431	456	506	556	606	656	
SVI206/..	0,75	80	373					207	231	256	281	331	356	381	406	431	456	506	556	606	656	
SVI207/..	1,1	80	373						231	256	281	331	356	381	406	431	456	506	556	606	656	
SVI208/..	1,1	80	373							256	281	331	356	381	406	431	456	506	556	606	656	
SVI209/..	1,1	80	373								281	331	356	381	406	431	456	506	556	606	656	
SVI211/..	1,5	90	418									331	356	381	406	431	456	506	556	606	656	
SVI212/..	1,5	90	418										356	381	406	431	456	506	556	606	656	
SVI214/..	2,2	90	418											406	431	456	506	556	606	656	656	
SVI216/..	2,2	90	418												456	506	556	606	656	656	656	
SVI218/..	2,2	90	418													506	556	606	656	656	656	
SVI220/..	3	100	428														556	606	656	656	656	
SVI222/..	3	100	428															606	656	656	656	
SV224/..	3	100	428																	656	656	

svi2s-en_b_tcm



ITT

Lowara

SVI 2 (S, N) SERIES OPERATING CHARACTERISTICS AT 50 Hz, 2 POLES

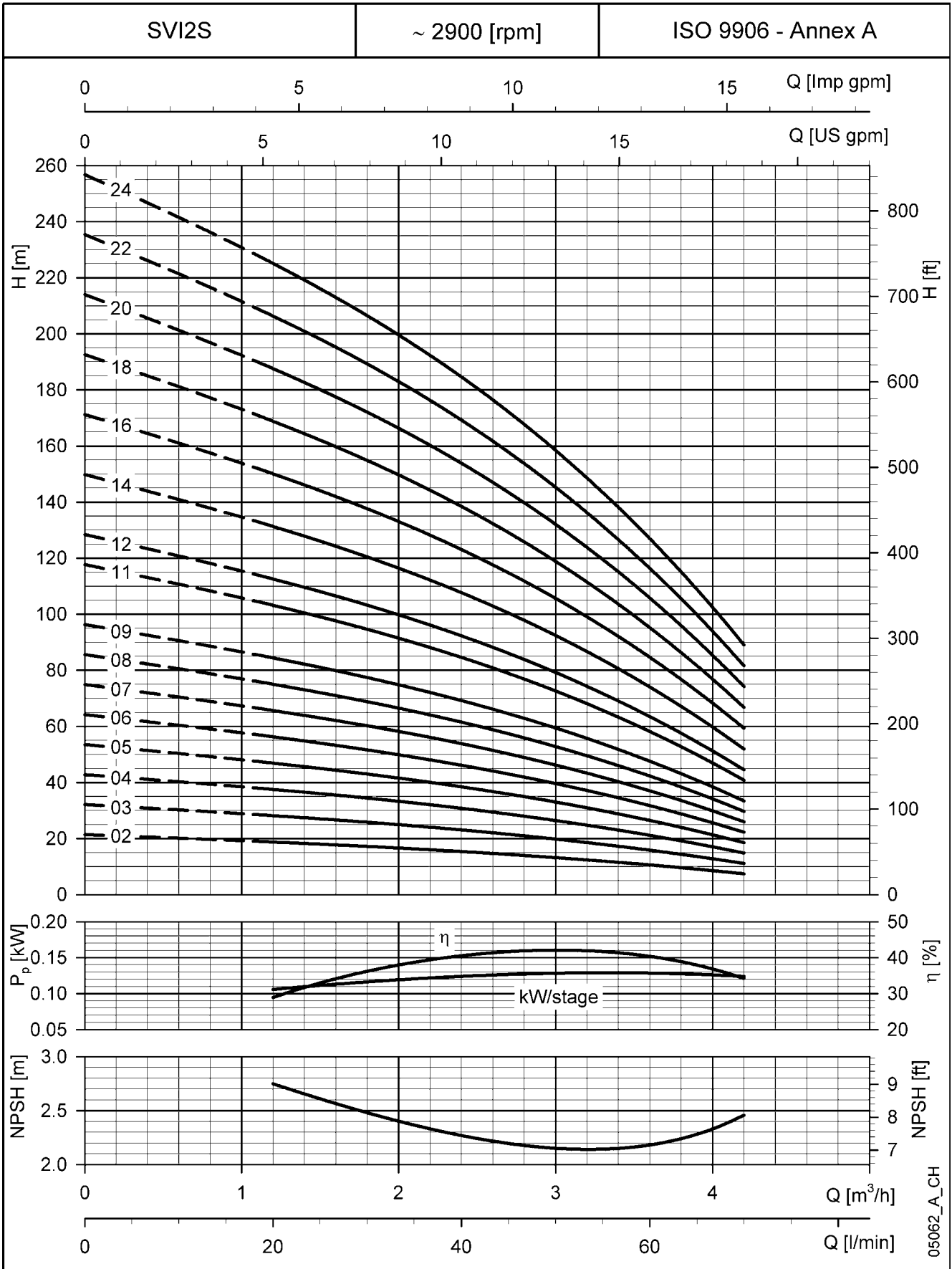

These performances are valid for liquids with density $\rho = 1.0 \text{ Kg/dm}^3$ and kinematic viscosity $\nu = 1 \text{ mm}^2/\text{sec}$.



ITT

Lowara

SVI 4 (S, N) SERIES DIMENSIONS AND WEIGHTS AT 50 Hz, 2 POLES

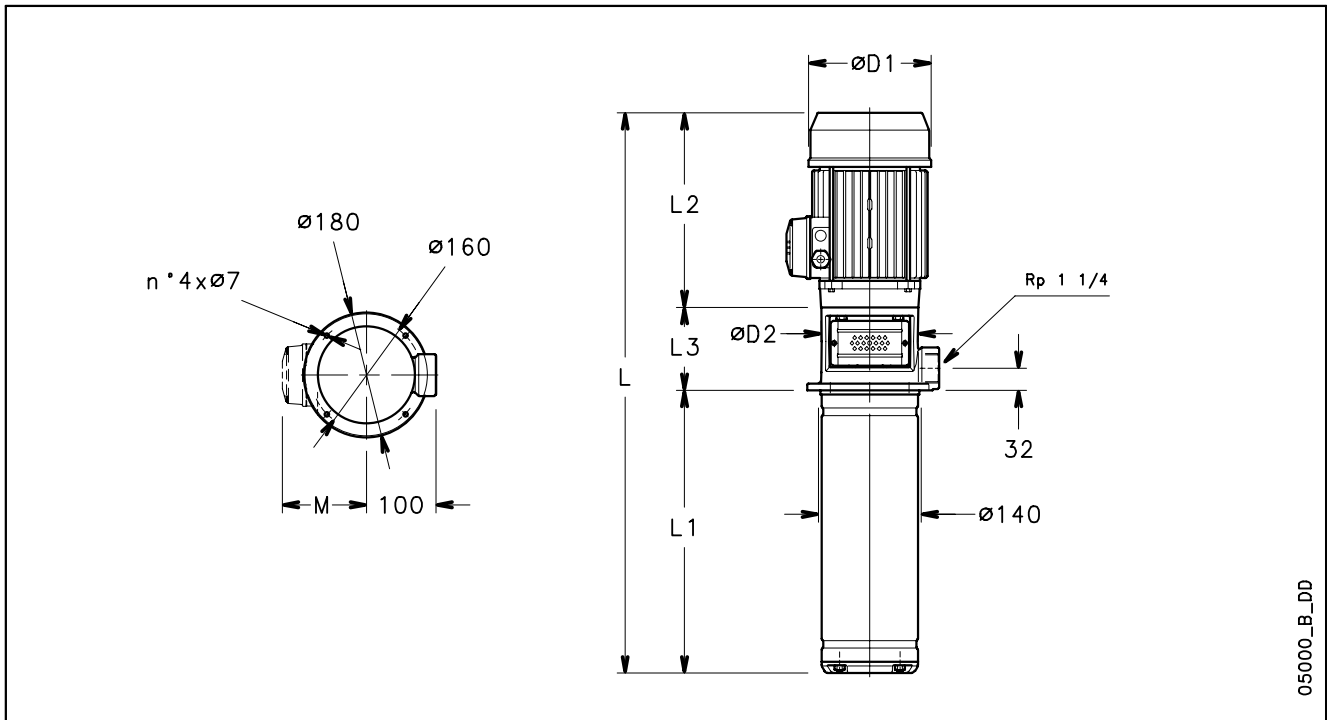

05000_B_DD

PUMP TYPE	MOTOR		DIMENSIONS (mm)							ELECTRIC PUMP WEIGHT	
	kW	SIZE	L	L1	L2	L3	M	D1	D2	kg	
SVI402/02S03T	0,37	71	416	107	209	100	111	120	105	14	
SVI403/03S05T	0,55	71	463	132	231	100	111	140	105	14	
SVI404/04S07T	0,75	80	530	157	263	110	129	155	120	20	
SVI405/05S11T	1,1	80	555	182	263	110	129	155	120	21	
SVI406/06S11T	1,1	80	580	207	263	110	129	155	120	21	
SVI407/07S11T	1,1	80	604	231	263	110	129	155	120	22	
SVI408/08S15T	1,5	90	674	256	298	120	134	174	140	29	
SVI409/09S15T	1,5	90	699	281	298	120	134	174	140	29	
SVI411/11S22T	2,2	90	749	331	298	120	134	174	140	31	
SVI413/13S22T	2,2	90	799	381	298	120	134	174	140	32	
SVI414/14S30T	3	100	834	406	298	130	134	174	160	35	
SVI416/16S30T	3	100	884	456	298	130	134	174	160	35	
SVI418/18S30T	3	100	934	506	298	130	134	174	160	35	
SVI420/20S40T	4	112	1005	556	319	130	154	197	160	51	
SVI422/22S40T	4	112	1055	606	319	130	154	197	160	51	
SVI424/24S40T	4	112	1105	656	319	130	154	197	160	52	

svi4s-2p50-en_c_td

NUMBER OF IMPELLERS	PUMP TYPE	MOTOR		DIMENS. L2+L3 mm	NUMBER OF STAGES																
		kW	SIZE		L1 Shank lengths in mm (AVAILABLE ON REQUEST)																
					2	3	4	5	6	7	8	9	11	12	13	14	15	16	18	20	22
SVI402/..	0,37	71	309	107	132	157	182	207	231	256	281	331	356	381	406	431	456	506	556	606	656
SVI403/..	0,55	71	331		132	157	182	207	231	256	281	331	356	381	406	431	456	506	556	606	656
SVI404/..	0,75	80	373			157	182	207	231	256	281	331	356	381	406	431	456	506	556	606	656
SVI405/..	1,1	80	373				182	207	231	256	281	331	356	381	406	431	456	506	556	606	656
SVI406/..	1,1	80	373					207	231	256	281	331	356	381	406	431	456	506	556	606	656
SVI407/..	1,1	80	373						231	256	281	331	356	381	406	431	456	506	556	606	656
SVI408/..	1,5	90	418							256	281	331	356	381	406	431	456	506	556	606	656
SVI409/..	1,5	90	418								281	331	356	381	406	431	456	506	556	606	656
SVI411/..	2,2	90	418									331	356	381	406	431	456	506	556	606	656
SVI413/..	2,2	90	418										381	406	431	456	506	556	606	656	
SVI414/..	3	100	428											406	431	456	506	556	606	656	
SVI416/..	3	100	428												456	506	556	606	656		
SVI418/..	3	100	428													506	556	606	656		
SVI420/..	4	112	449														556	606	656		
SVI422/..	4	112	449															606	656		
SVI424/..	4	112	449																656		

svi4s-en_b_tcm



ITT

Lowara

SVI 4 (S, N) SERIES OPERATING CHARACTERISTICS AT 50 Hz, 2 POLES

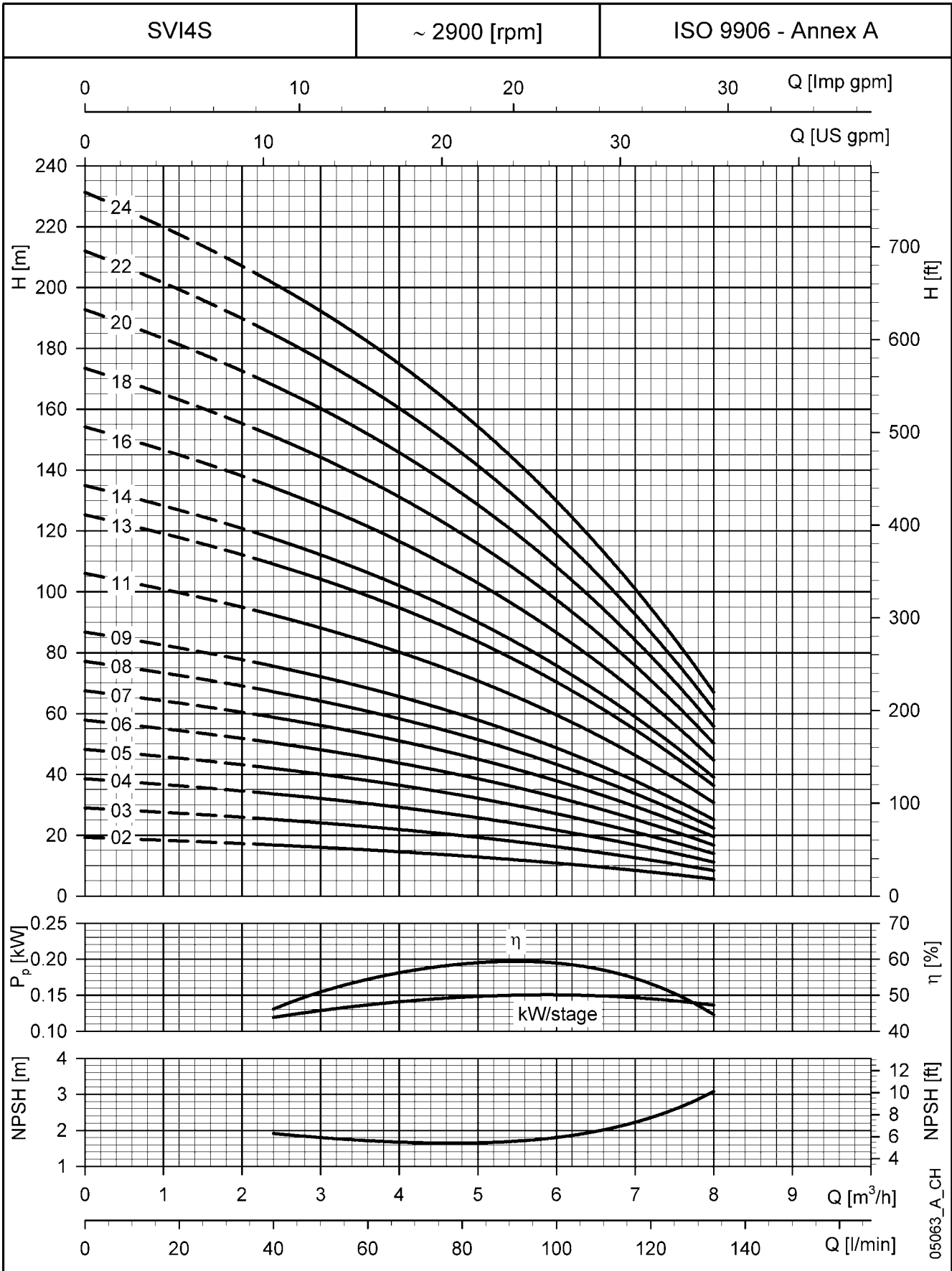

These performances are valid for liquids with density $\rho = 1.0 \text{ Kg/dm}^3$ and kinematic viscosity $\nu = 1 \text{ mm}^2/\text{sec}$.



ITT

Lowara

SVI 8 (S, N) SERIES DIMENSIONS AND WEIGHTS AT 50 Hz, 2 POLES

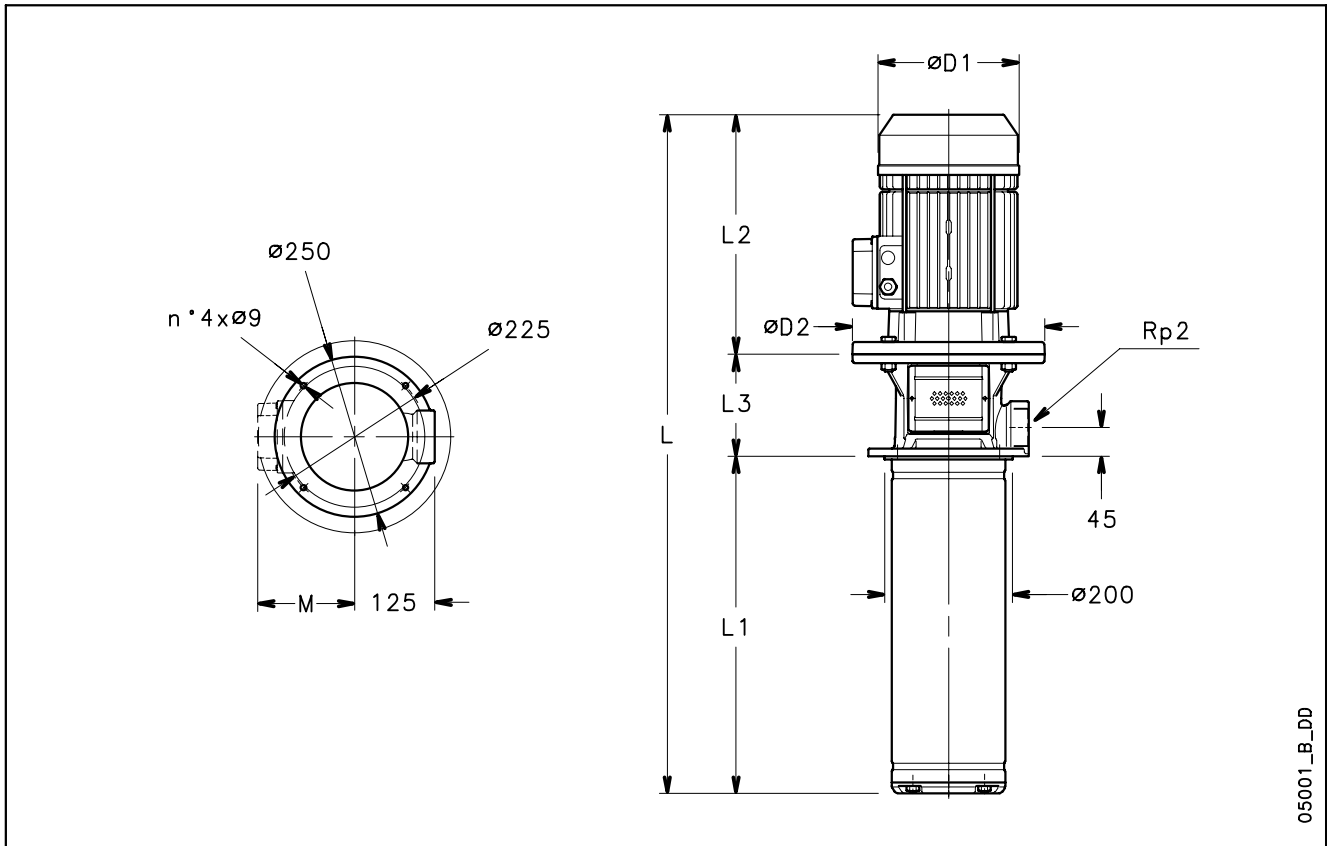

05001_B_DD

PUMP TYPE	MOTOR		DIMENSIONS (mm)							ELECTRIC PUMP WEIGHT	
	kW	SIZE	L	L1	L2	L3	M	D1	D2	kg	
SVI801/02S07T	0,75	80	528	146	263	119	129	155	120	25	
SVI802/02S11T	1,1	80	528	146	263	119	129	155	120	26	
SVI803/03S15T	1,5	90	611	184	298	129	134	174	140	33	
SVI804/04S22T	2,2	90	649	222	298	129	134	174	140	35	
SVI805/05S22T	2,2	90	687	260	298	129	134	174	140	36	
SVI806/06S30T	3	100	735	298	298	139	134	174	160	40	
SVI808/08S40T	4	112	832	374	319	139	154	197	160	57	
SVI809/09S40T	4	112	870	412	319	139	154	197	160	58	
SVI811/11S55T	5,5	132	1022	488	375	159	168	214	300	69	
SVI812/12S55T	5,5	132	1060	526	375	159	168	214	300	70	
SVI814/14S75T	7,5	132	1128	602	367	159	191	256	300	88	
SVI816/16S75T	7,5	132	1204	678	367	159	191	256	300	89	

svi8s-2p50-en_c_td

NUMBER OF IMPELLERS	PUMP TYPE	MOTOR		DIMENS. L2+L3 mm	NUMBER OF STAGES													
		kW	SIZE		2	3	4	5	6	7	8	9	10	11	12	14	15	16
		L1 Shank lengths in mm (AVAILABLE ON REQUEST)																
	SVI801/..	0,75	80	382	146	184	222	260	298	336	374	412	450	488	526	602	640	678
	SVI802/..	1,1	80	382	146	184	222	260	298	336	374	412	450	488	526	602	640	678
	SVI803/..	1,5	90	427		184	222	260	298	336	374	412	450	488	526	602	640	678
	SVI804/..	2,2	90	427			222	260	298	336	374	412	450	488	526	602	640	678
	SVI805/..	2,2	90	427				260	298	336	374	412	450	488	526	602	640	678
	SVI806/..	3	100	437					298	336	374	412	450	488	526	602	640	678
	SVI808/..	4	112	458							374	412	450	488	526	602	640	678
	SVI809/..	4	112	458								412	450	488	526	602	640	678
	SVI811/..	5,5	132	534										488	526	602	640	678
	SVI812/..	5,5	132	534											526	602	640	678
	SVI814/..	7,5	132	526												602	640	678
	SVI816/..	7,5	132	526													640	678

svi8s-en_b_tcm



ITT

Lowara

SVI 8 (S, N) SERIES OPERATING CHARACTERISTICS AT 50 Hz, 2 POLES

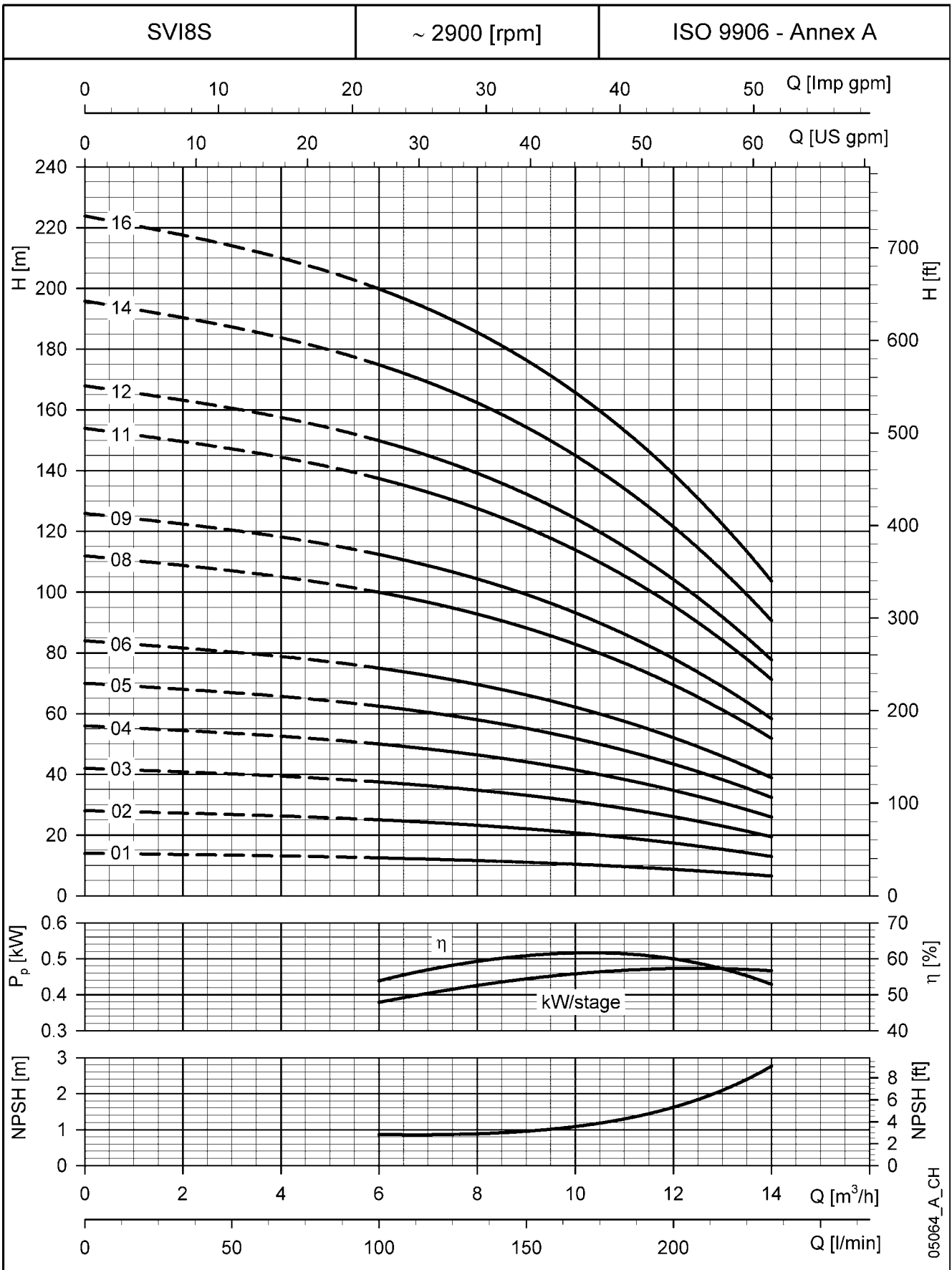

These performances are valid for liquids with density $\rho = 1.0 \text{ Kg/dm}^3$ and kinematic viscosity $\nu = 1 \text{ mm}^2/\text{sec}$.



ITT

Lowara

SVI 16 (S, N) SERIES DIMENSIONS AND WEIGHTS AT 50 Hz, 2 POLES

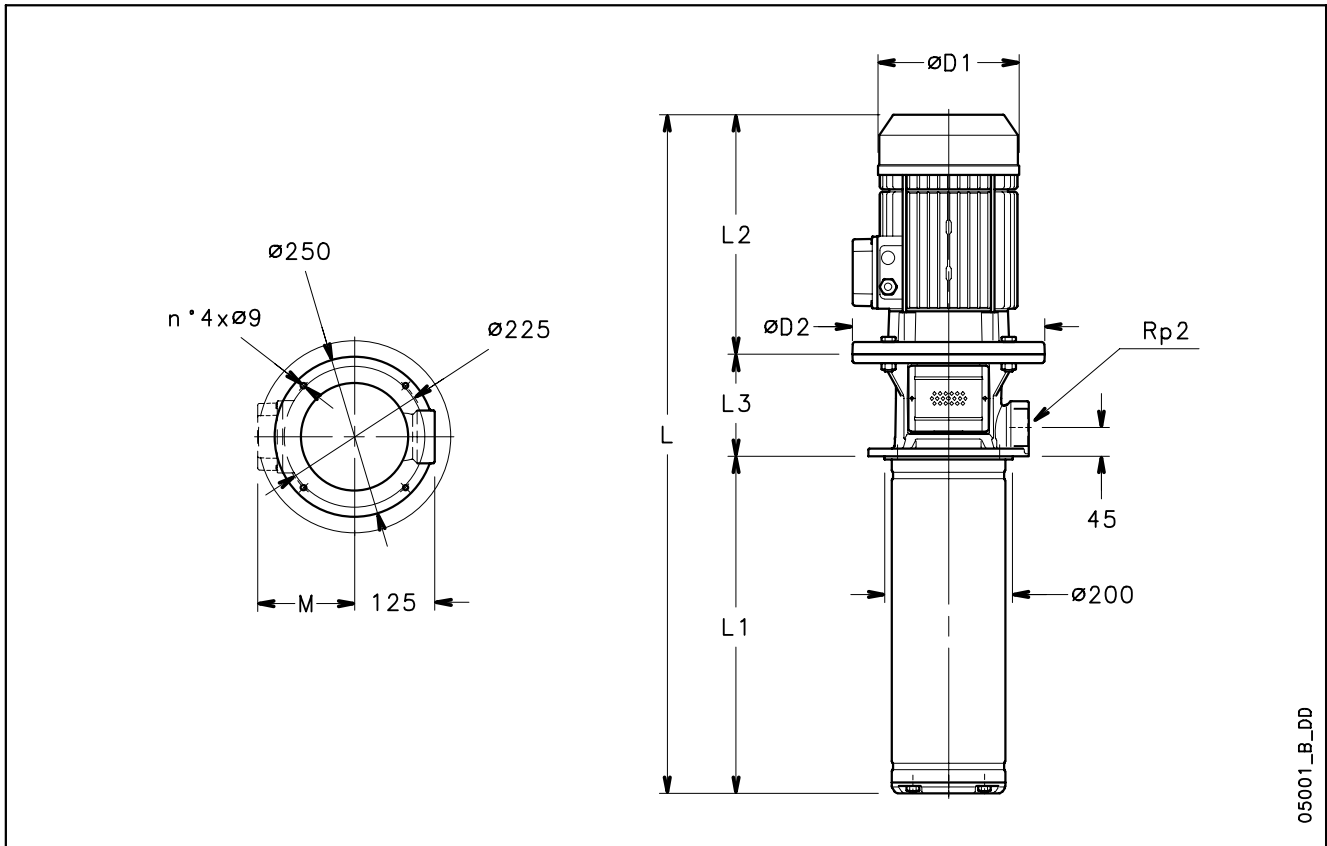

05001_B_DD

PUMP TYPE	MOTOR		DIMENSIONS (mm)							ELECTRIC PUMP WEIGHT	
	kW	SIZE	L	L1	L2	L3	M	D1	D2	kg	
SVI1601/02S11T	1,1	80	528	146	263	119	129	155	120	28	
SVI1602/02S22T	2,2	90	573	146	298	129	134	174	140	35	
SVI1603/03S30T	3	100	621	184	298	139	134	174	160	39	
SVI1604/04S40T	4	112	680	222	319	139	154	197	160	57	
SVI1605/05S55T	5,5	132	794	260	375	159	168	214	300	67	
SVI1606/06S55T	5,5	132	832	298	375	159	168	214	300	68	
SVI1607/07S75T	7,5	132	862	336	367	159	191	256	300	85	
SVI1608/08S75T	7,5	132	900	374	367	159	191	256	300	86	
SVI1610/10S110T	11	160	1069	450	428	191	191	256	350	119	
SVI1612/12S110T	11	160	1145	526	428	191	191	256	350	121	
SVI1614/14S150T	15	160	1287	602	494	191	240	313	350	130	
SVI1615/15S150T	15	160	1325	640	494	191	240	313	350	131	

svi16s-2p50-en_c_td

NUMBER OF IMPELLERS	PUMP TYPE	MOTOR		DIMENS. L2+L3 mm	NUMBER OF STAGES													
		kW	SIZE		2	3	4	5	6	7	8	9	10	11	12	14	15	16
					L1 Shank lengths in mm (AVAILABLE ON REQUEST)													
	SVI1601/..	1,1	80	382	146	184	222	260	298	336	374	412	450	488	526	602	640	678
	SVI1602/..	2,2	90	427	146	184	222	260	298	336	374	412	450	488	526	602	640	678
	SVI1603/..	3	100	437		184	222	260	298	336	374	412	450	488	526	602	640	678
	SVI1604/..	4	112	458			222	260	298	336	374	412	450	488	526	602	640	678
	SVI1605/..	5,5	132	534				260	298	336	374	412	450	488	526	602	640	678
	SVI1606/..	5,5	132	534					298	336	374	412	450	488	526	602	640	678
	SVI1607/..	7,5	132	526						336	374	412	450	488	526	602	640	678
	SVI1608/..	7,5	132	526							374	412	450	488	526	602	640	678
	SVI1610/..	11	160	619									450	488	526	602	640	678
	SVI1612/..	11	160	619											526	602	640	678
	SVI1614/..	15	160	685												602	640	678
	SVI1615/..	15	160	685													640	678

svi16s-en_b_tcm



ITT

Lowara

SVI 16 (S, N) SERIES OPERATING CHARACTERISTICS AT 50 Hz, 2 POLES

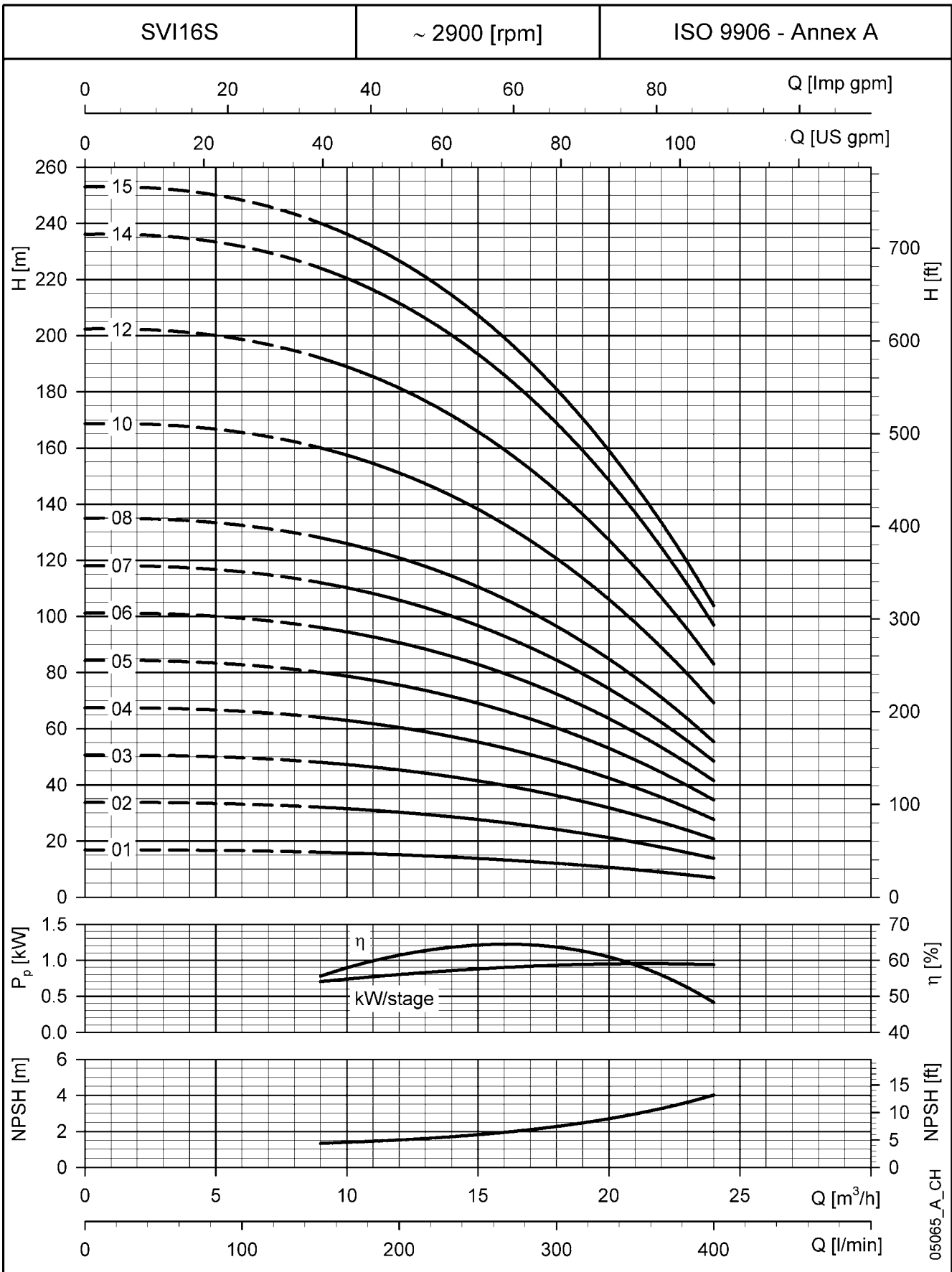

These performances are valid for liquids with density $\rho = 1.0 \text{ Kg/dm}^3$ and kinematic viscosity $\nu = 1 \text{ mm}^2/\text{sec}$.



ITT

Lowara

SVI 33 (S, N) SERIES DIMENSIONS AND WEIGHTS AT 50 Hz, 2 POLES

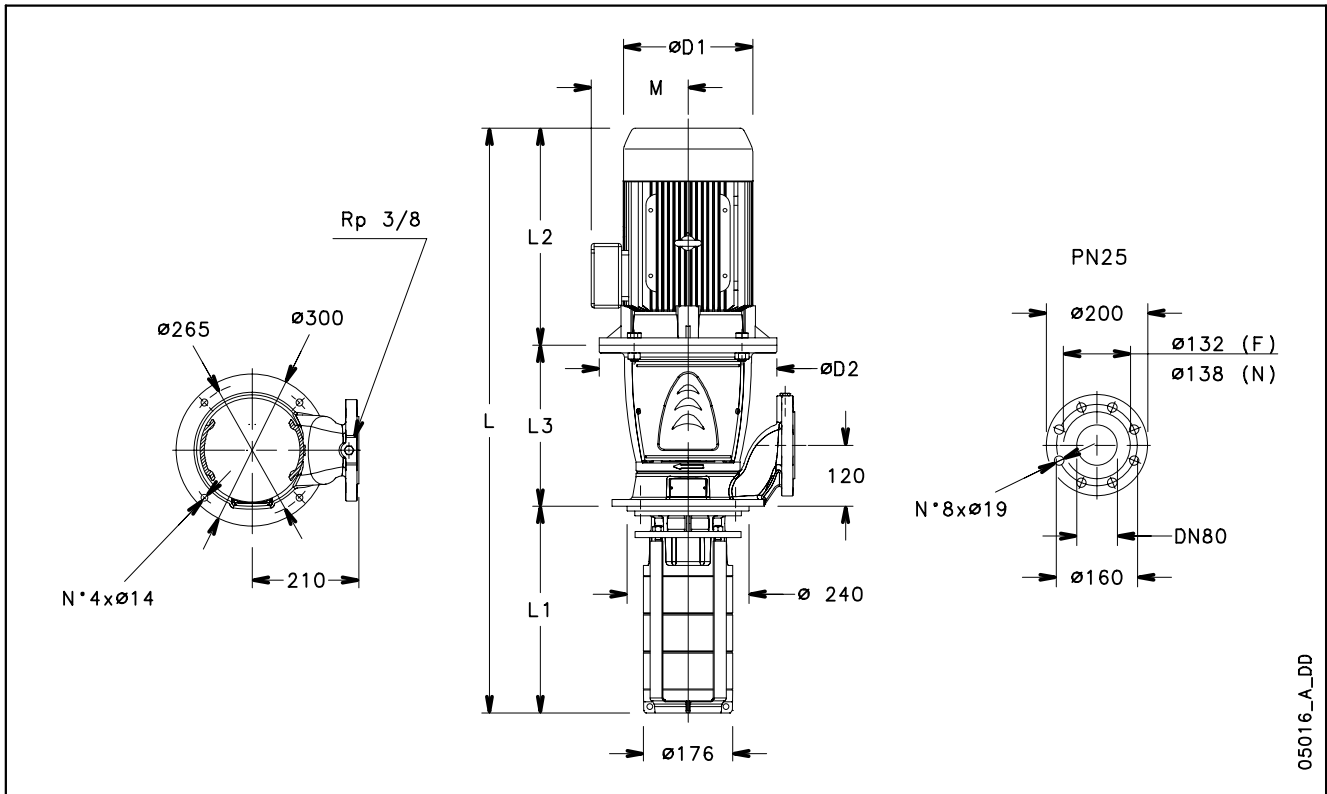

05016_A_DD

PUMP TYPE	MOTOR		DIMENSIONS (mm)							ELECTRIC PUMP WEIGHT kg
	kW	SIZE	L	L1	L2	L3	M	D1	D2	
SVI3301/1-01S22T	2,2	90	817	257	298	262	134	174	140	56
SVI3301-01S30T	3	100	817	257	298	262	134	174	160	64
SVI3302/2-02S40T	4	112	913	332	319	262	154	197	160	70
SVI3302/1-02S40T	4	112	913	332	319	262	154	197	160	70
SVI3303/2-03S55T	5,5	132	1064	407	375	282	168	214	300	88
SVI3303-03S75T	7,5	132	1056	407	367	282	191	256	300	107
SVI3304-04S110T	11	160	1227	482	428	317	191	256	350	128
SVI3305/1-05S110T	11	160	1302	557	428	317	191	256	350	130
SVI3306/2-06S150T	15	160	1443	632	494	317	240	313	350	165
SVI3307/2-07S150T	15	160	1518	707	494	317	240	313	350	168
SVI3307-07S185T	18,5	160	1518	707	494	317	240	313	350	176
SVI3308/1-08S185T	18,5	160	1593	782	494	317	240	313	350	179
SVI3309/1-09S220T	22	180	1668	857	494	317	240	313	350	193
SVI3310/2-10S220T	22	180	1743	932	494	317	240	313	350	196
SVI3310-10S300T	30	200	1906	932	657	317	317	402	400	303

svi33s-2p50-en_b_td

PUMP TYPE	MOTOR		DIMENS. L2+L3 mm	NUMBER OF STAGES											
	kW	SIZE		1	2	3	4	5	6	7	8	9	10	11	12
	L1 Shank lengths in mm (AVAILABLE ON REQUEST)														
SVI3301/1-..	2,2	90	560	257	332	407	482	557	632	707	782	857	932	1007	1082
SVI3301-..	3	100	560	257	332	407	482	557	632	707	782	857	932	1007	1082
SVI3302/2-..	4	112	581		332	407	482	557	632	707	782	857	932	1007	1082
SVI3302/1-..	4	112	581		332	407	482	557	632	707	782	857	932	1007	1082
SVI3303/2-..	5,5	132	657			407	482	557	632	707	782	857	932	1007	1082
SVI3303-..	7,5	132	649			407	482	557	632	707	782	857	932	1007	1082
SVI3304-..	11	160	745				482	557	632	707	782	857	932	1007	1082
SVI3305/1-..	11	160	745					557	632	707	782	857	932	1007	1082
SVI3306/2-..	15	160	811						632	707	782	857	932	1007	1082
SVI3307/2-..	15	160	811							707	782	857	932	1007	1082
SVI3307-..	18,5	160	811							707	782	857	932	1007	1082
SVI3308/1-..	18,5	160	811								782	857	932	1007	1082
SVI3309/1-..	22	180	811									857	932	1007	1082
SVI3310/2-..	22	180	811										932	1007	1082
SVI3310-..	30	200	974										932	1007	1082

svi33s-en_b_tcm



ITT

Lowara

SVI 33 (S, N) SERIES OPERATING CHARACTERISTICS AT 50 Hz, 2 POLES

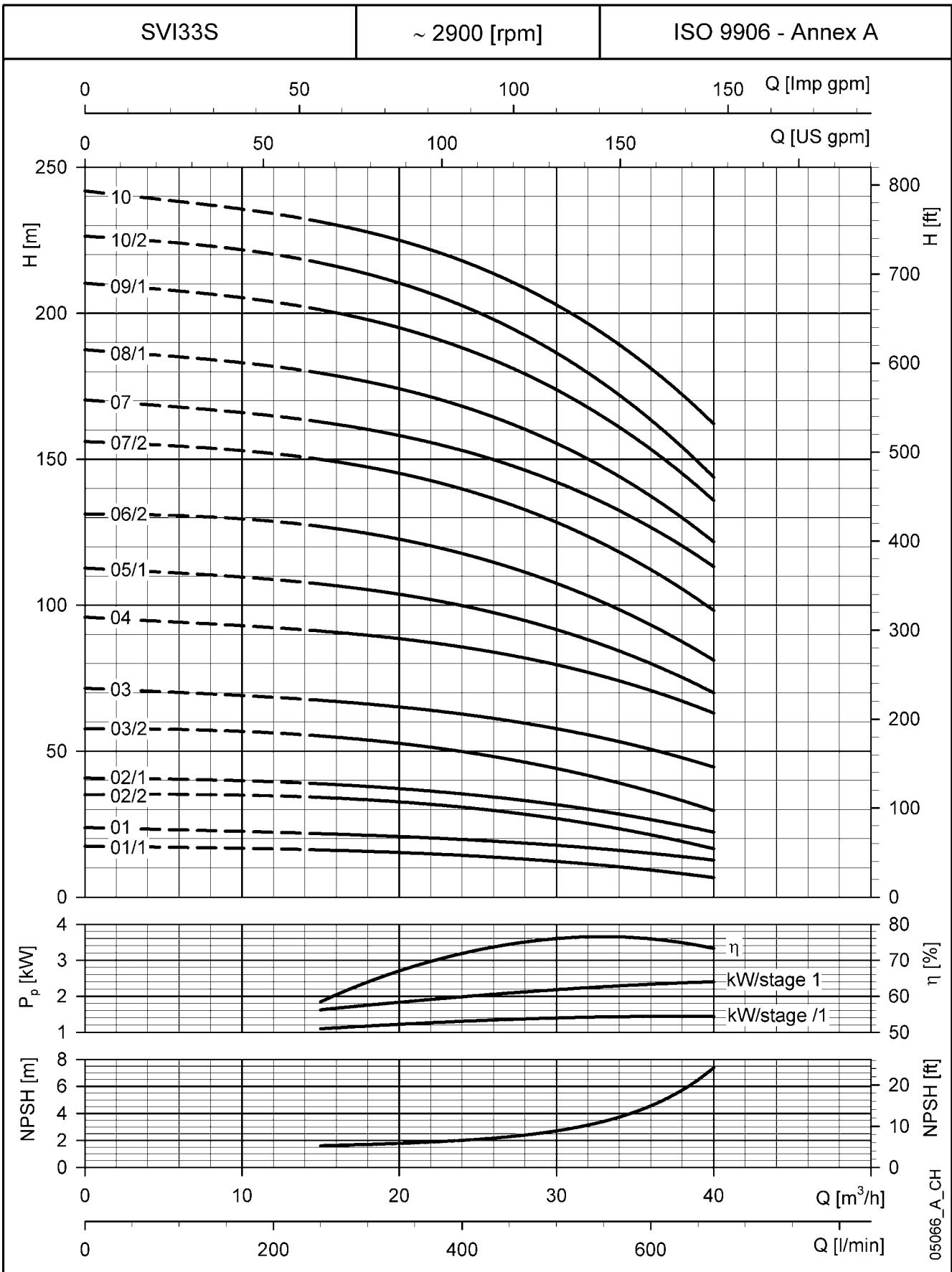

These performances are valid for liquids with density $\rho = 1.0 \text{ Kg/dm}^3$ and kinematic viscosity $\nu = 1 \text{ mm}^2/\text{sec}$.



ITT

Lowara

SVI 46 (S, N) SERIES DIMENSIONS AND WEIGHTS AT 50 Hz, 2 POLES

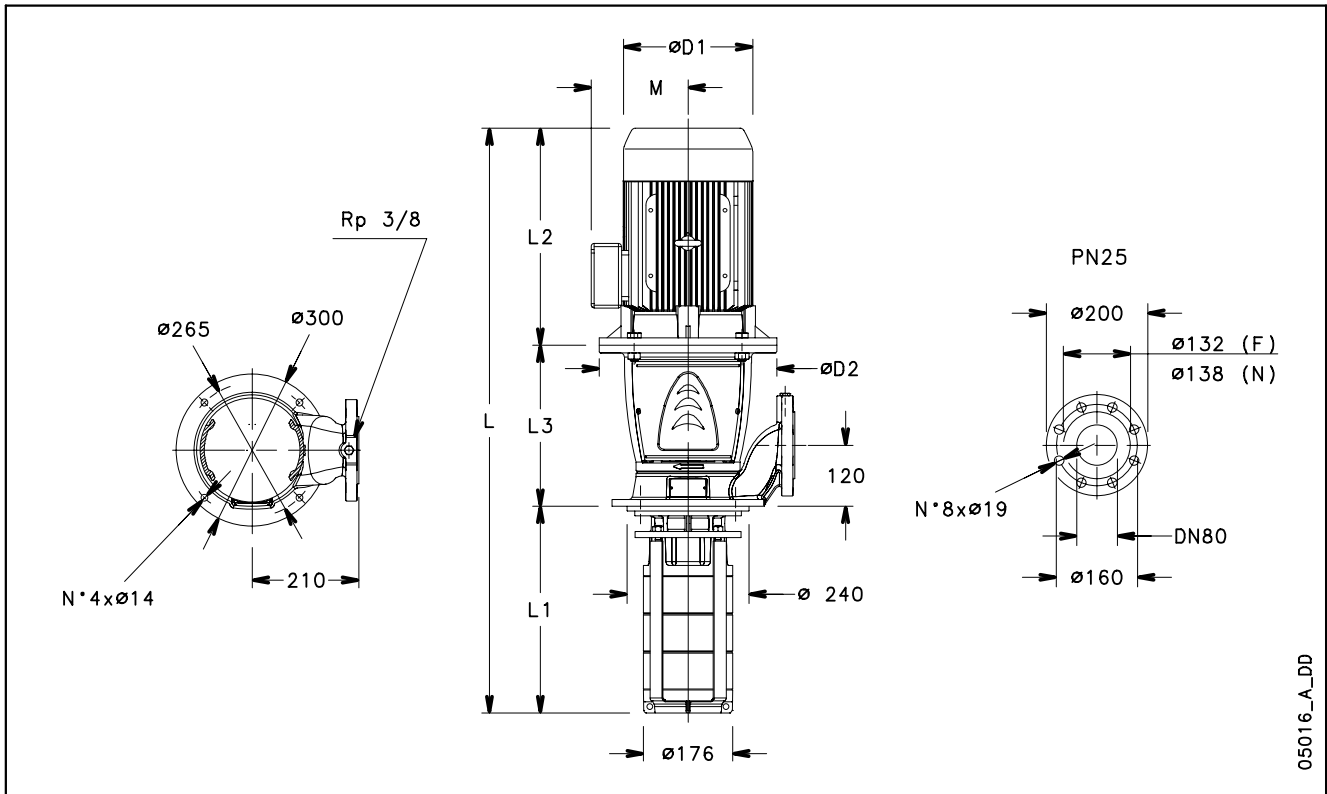

PUMP TYPE	MOTOR		DIMENSIONS (mm)							ELECTRIC PUMP WEIGHT	
	kW	SIZE	L	L1	L2	L3	M	D1	D2	kg	
SVI4601/1-01S30T	3	100	817	257	298	262	134	174	160	64	
SVI4601-01S40T	4	112	838	257	319	262	154	197	160	67	
SVI4602/2-02S55T	5,5	132	989	332	375	282	168	214	300	85	
SVI4602-02S75T	7,5	132	981	332	367	282	191	256	300	104	
SVI4603-03S110T	11	160	1152	407	428	317	191	256	350	125	
SVI4604/2-04S150T	15	160	1293	482	494	317	240	313	350	159	
SVI4605-05S185T	18,5	160	1368	557	494	317	240	313	350	171	
SVI4606-06S220T	22	180	1443	632	494	317	240	313	350	185	
SVI4607/2-07S300T	30	200	1681	707	657	317	317	402	400	301	
SVI4608/2-08S300T	30	200	1756	782	657	317	317	402	400	304	
SVI4609/2-09S300T	30	200	1831	857	657	317	317	402	400	306	

svi46s-2p50-en_b_tcm

NUMBER OF IMPELLERS	PUMP TYPE	MOTOR		DIMENS. L2+L3 mm	NUMBER OF STAGES											
		kW	SIZE		1	2	3	4	5	6	7	8	9	10	11	12
					L1 Shank lengths in mm (AVAILABLE ON REQUEST)											
	SVI4601/1-..	3	100	560	257	332	407	482	557	632	707	782	857	932	1007	1082
	SVI4601-..	4	112	581	257	332	407	482	557	632	707	782	857	932	1007	1082
	SVI4602/2-..	5,5	132	657		332	407	482	557	632	707	782	857	932	1007	1082
	SVI4602-..	7,5	132	649		332	407	482	557	632	707	782	857	932	1007	1082
	SVI4603-..	11	160	745			407	482	557	632	707	782	857	932	1007	1082
	SVI4604/2-..	15	160	811				482	557	632	707	782	857	932	1007	1082
	SVI4605-..	18,5	160	811					557	632	707	782	857	932	1007	1082
	SVI4606-..	22	180	811						632	707	782	857	932	1007	1082
	SVI4607/2-..	30	200	974							707	782	857	932	1007	1082
	SVI4608/2-..	30	200	974								782	857	932	1007	1082
	SVI4609/2-..	30	200	974									857	932	1007	1082

svi46s-en_b_tcm



ITT

Lowara

SVI 46 (S, N) SERIES OPERATING CHARACTERISTICS AT 50 Hz, 2 POLES

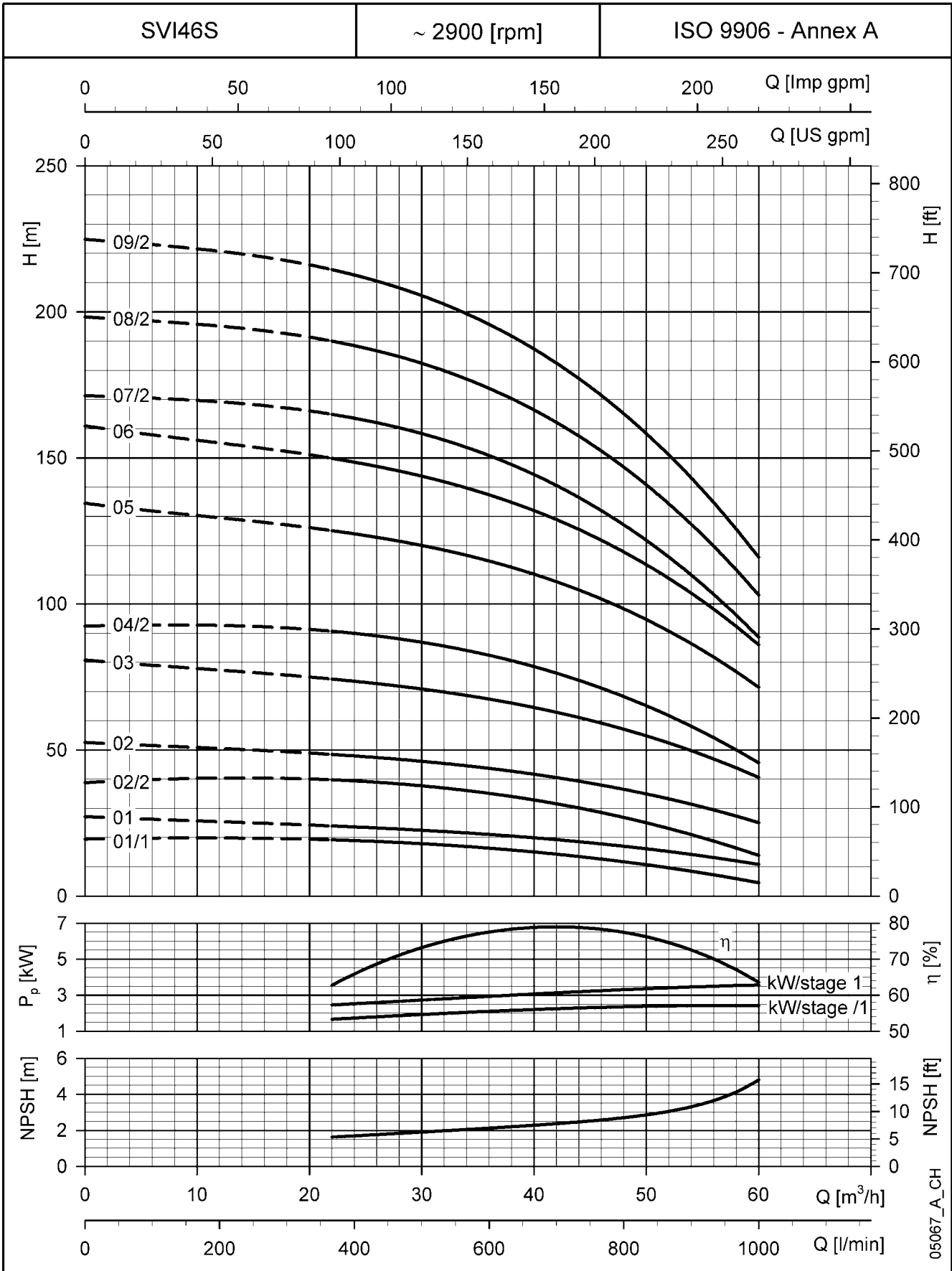

These performances are valid for liquids with density $\rho = 1.0 \text{ Kg/dm}^3$ and kinematic viscosity $\nu = 1 \text{ mm}^2/\text{sec}$.



ITT

Lowara

SVI 66 (S, N) SERIES DIMENSIONS AND WEIGHTS AT 50 Hz, 2 POLES

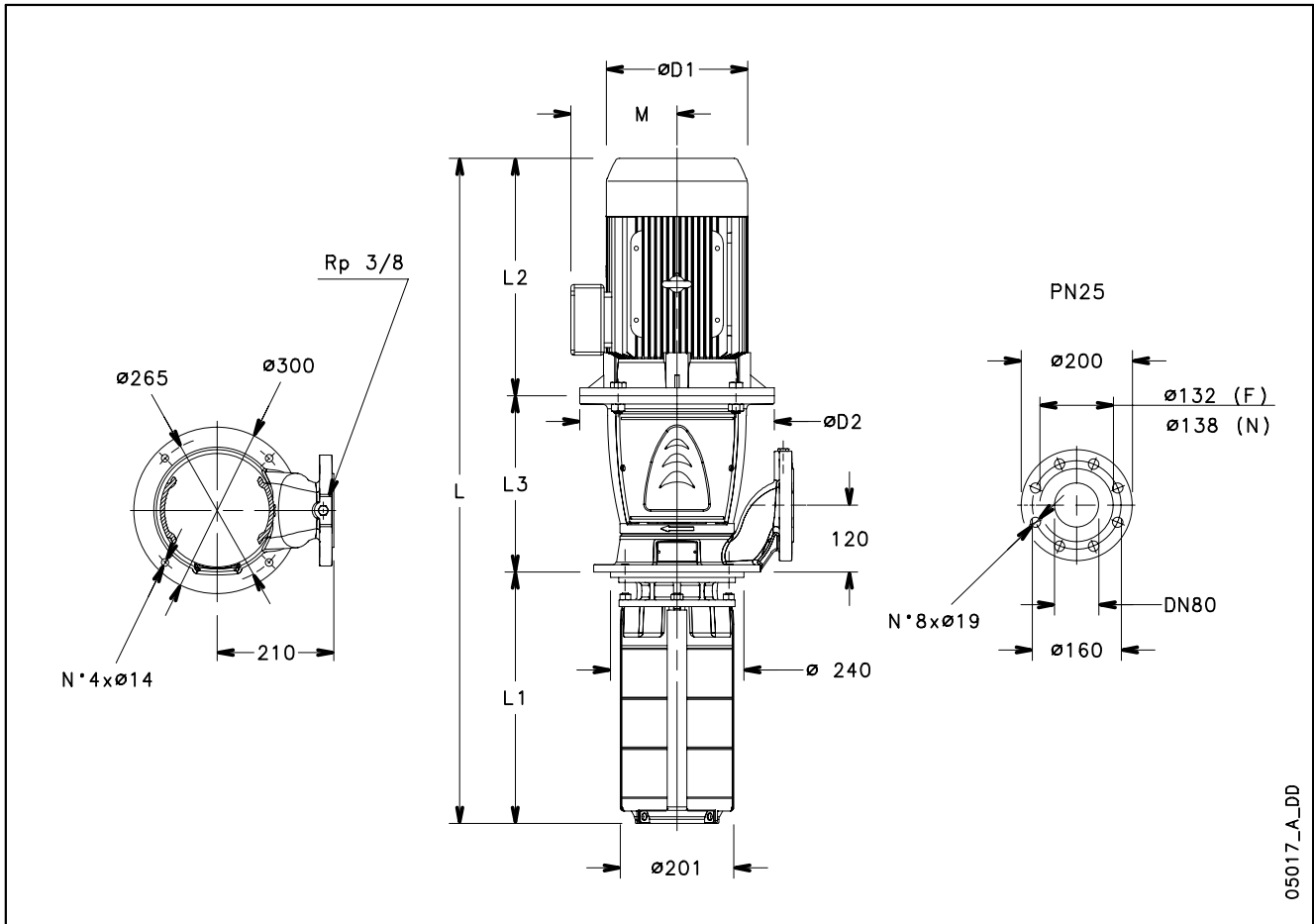

PUMP TYPE	MOTOR		DIMENSIONS (mm)							ELECTRIC PUMP WEIGHT	
	kW	SIZE	L	L1	L2	L3	M	D1	D2	kg	
SVI6601/1-01S40T	4	112	853	272	319	262	154	197	160	73	
SVI6601-01S55T	5,5	132	929	272	375	282	168	214	300	83	
SVI6602/2-02S75T	7,5	132	1011	362	367	282	191	256	300	109	
SVI6602-02S110T	11	160	1107	362	428	317	191	256	350	124	
SVI6603/2-03S150T	15	160	1263	452	494	317	240	313	350	159	
SVI6603-03S185T	18,5	160	1263	452	494	317	240	313	350	160	
SVI6604/1-04S220T	22	180	1353	542	494	317	240	313	350	190	
SVI6605/1-05S300T	30	200	1606	632	657	317	317	402	400	299	

svi66s-2p50-en_b_td

NUMBER OF IMPELLERS	PUMP TYPE	MOTOR		DIMENS. L2+L3 mm	NUMBER OF STAGES									
		kW	SIZE		1	2	3	4	5	6	7	8	9	10
		L1 Shank lengths in mm (AVAILABLE ON REQUEST)												
	SVI6601/1-..	4	112	581	272	362	452	542	632	722	812	902	992	1082
	SVI6601-..	5,5	132	657	272	362	452	542	632	722	812	902	992	1082
	SVI6602/2-..	7,5	132	649		362	452	542	632	722	812	902	992	1082
	SVI6602-..	11	160	745		362	452	542	632	722	812	902	992	1082
	SVI6603/2-..	15	160	811			452	542	632	722	812	902	992	1082
	SVI6603-..	18,5	160	811			452	542	632	722	812	902	992	1082
	SVI6604/1-..	22	180	811				542	632	722	812	902	992	1082
	SVI6605/1-..	30	200	974					632	722	812	902	992	1082

svi66s-en_b_tcm



ITT

Lowara

SVI 66 (S, N) SERIES OPERATING CHARACTERISTICS AT 50 Hz, 2 POLES

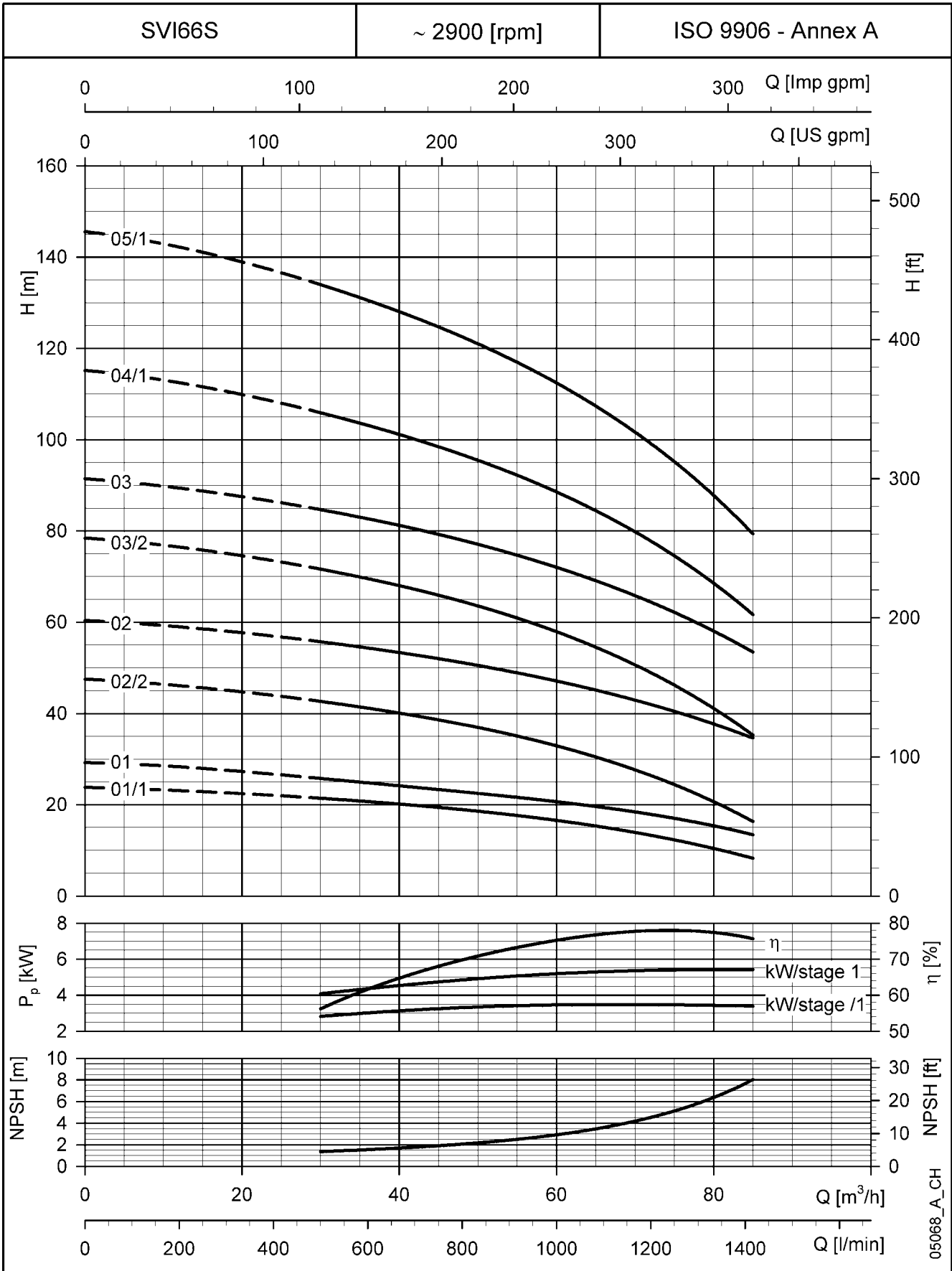

These performances are valid for liquids with density $\rho = 1.0 \text{ Kg/dm}^3$ and kinematic viscosity $\nu = 1 \text{ mm}^2/\text{sec}$.



ITT

Lowara

SVI 92 (S, N) SERIES DIMENSIONS AND WEIGHTS AT 50 Hz, 2 POLES

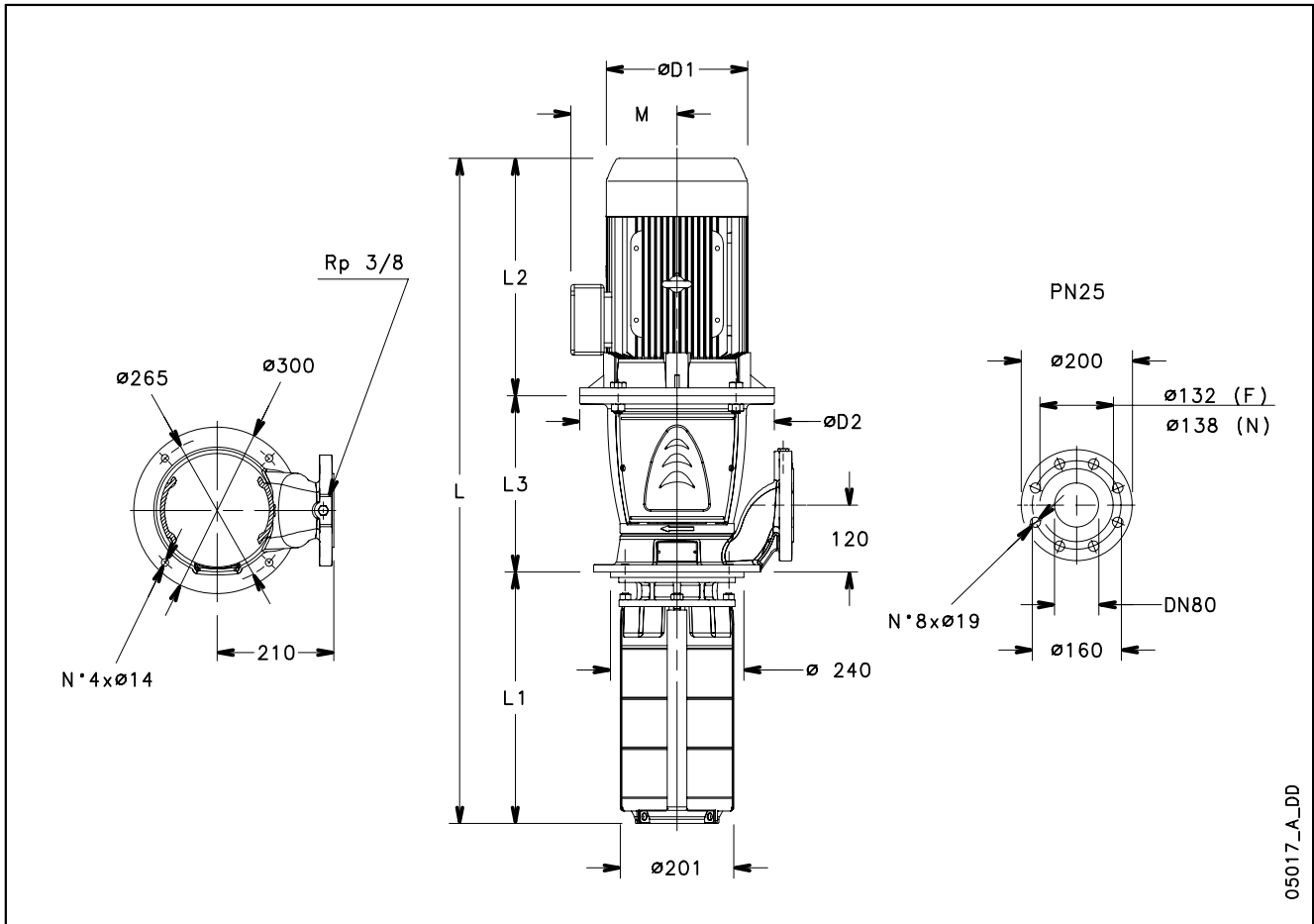

05017_A_DD

PUMP TYPE	MOTOR		DIMENSIONS (mm)							ELECTRIC PUMP WEIGHT	
	kW	SIZE	L	L1	L2	L3	M	D1	D2	kg	
SVI9201/1-01S55T	5,5	132	929	272	375	282	168	214	300	83	
SVI9201-01S75T	7,5	132	921	272	367	282	191	256	300	101	
SVI9202/2-02S110T	11	160	1107	362	428	317	191	256	350	123	
SVI9202-02S150T	15	160	1173	362	494	317	240	313	350	155	
SVI9203/2-03S185T	18,5	160	1263	452	494	317	240	313	350	167	
SVI9203-03S220T	22	180	1263	452	494	317	240	313	350	179	
SVI9204/2-04S300T	30	200	1516	542	657	317	317	402	400	296	
SVI9204-04S300T	30	200	1516	542	657	317	317	402	400	296	

svi92s-2p50-en_b_td

NUMBER OF IMPELLERS	PUMP TYPE	MOTOR		DIMENS. L2+L3 mm	NUMBER OF STAGES									
		kW	SIZE		1	2	3	4	5	6	7	8	9	10
		L1 Shank lengths in mm (AVAILABLE ON REQUEST)												
	SVI9201/1-..	5,5	132	657	272	362	452	542	632	722	812	902	992	1082
	SVI9201-..	7,5	132	649	272	362	452	542	632	722	812	902	992	1082
	SVI9202/2-..	11	160	745		362	452	542	632	722	812	902	992	1082
	SVI9202-..	15	160	811		362	452	542	632	722	812	902	992	1082
	SVI9203/2-..	18,5	160	811			452	542	632	722	812	902	992	1082
	SVI9203-..	22	180	811			452	542	632	722	812	902	992	1082
	SVI9204/2-..	30	200	974				542	632	722	812	902	992	1082
	SVI9204-..	30	200	974				542	632	722	812	902	992	1082

svi92s-en_b_tcm



ITT

Lowara

SVI 92 (S, N) SERIES OPERATING CHARACTERISTICS AT 50 Hz, 2 POLES

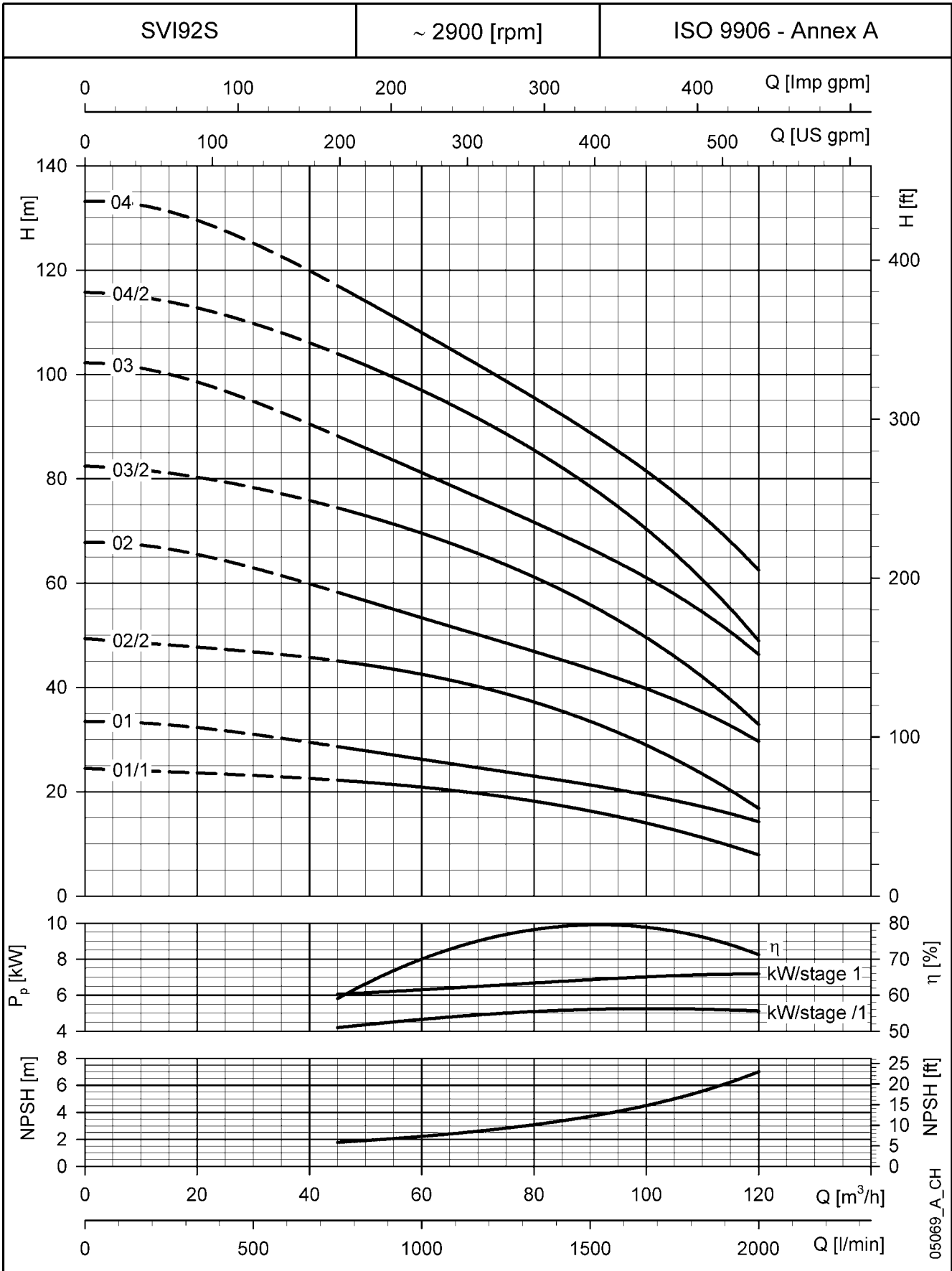

These performances are valid for liquids with density $\rho = 1.0 \text{ Kg/dm}^3$ and kinematic viscosity $\nu = 1 \text{ mm}^2/\text{sec}$.

SVI 33, 46, 66, 92 SERIES (S, N VERSIONS) DIMENSIONS OF ROUND THREADED COUNTERFLANGES

PUMP TYPE	DN	ø C	DIMENSIONS (mm)				HOLES		PN
			ø A	B	ø D	H	ø F	N°	
SVI33	80	Rp 3	160	17	200	27	18	8	16
SVI46									
SVI66									
SVI92									

svi-ctf-tonde-f-en_a_td

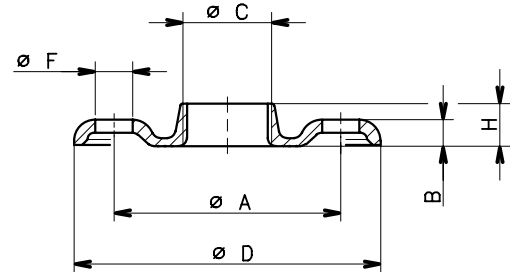

04430_B_DD

SVI 33, 46, 66, 92 SERIES (S, N VERSIONS) DIMENSIONS PF ROUND WELD-ON COUNTERFLANGES

PUMP TYPE	DN	ø C	DIMENSIONS (mm)			HOLES		PN
			ø A	B	ø D	ø F	N°	
SVI33	80	90	160	20	200	18	8	16
SVI46								
SVI66								
SVI92								
SVI33	80	90	160	24	200	18	8	25
SVI46								
SVI66								
SVI92								

svi-ctf-tonde-s-en_a_td

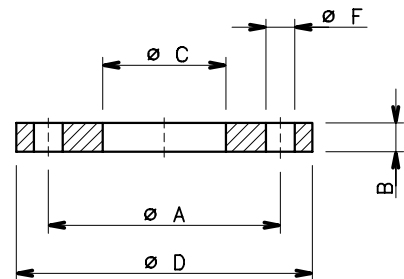

04431_A_DD

ROUND COUNTERFLANGES

- SVI 33, 46, 66, 92 S versions : Kit containing weld-on counterflange (PN16, PN25) or threaded one PN16 made of galvanized steel. Each Kit contains 1 counterflange plus bolts and gasket.
- SVI 33, 46, 66, 92 N versions : Kit containing weld-on counterflange (PN16, PN25) or threaded one PN16 made of AISI 316L stainless steel. Each Kit contains 1 counterflange plus bolts and gasket.



ITT

Lowara

INSTALLATION

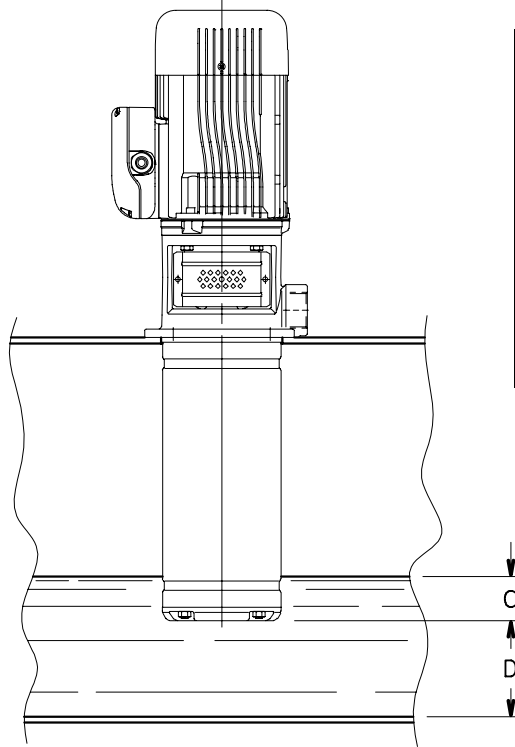

MINIMUM IMMERSION LEVEL		DISTANCE FROM THE BOTTOM	
PUMP TYPE	DIMENSION C mm	D mm	
		MINIMUM	RECOMMENDED
SVI2 SVI4	25	20	60
SVI8 SVI16	25	35	80
SVI33-46 SVI66-92	80	60	120

svi-liv-liq-en_a_td

05005_A_SC



Lowara



ITT

Lowara

TECHNICAL APPENDIX

NPSH

The minimum operating values that can be reached at the pump suction end are limited by the onset of cavitation.

Cavitation is the formation of vapour-filled cavities within liquids where the pressure is locally reduced to a critical value, or where the local pressure is equal to, or just below the vapour pressure of the liquid.

The vapour-filled cavities flow with the current and when they reach a higher pressure area the vapour contained in the cavities condenses. The cavities collide, generating pressure waves that are transmitted to the walls. These, being subjected to stress cycles, gradually become deformed and yield due to fatigue. This phenomenon, characterized by a metallic noise produced by the hammering on the pipe walls, is called incipient cavitation.

The damage caused by cavitation may be magnified by electrochemical corrosion and a local rise in temperature due to the plastic deformation of the walls. The materials that offer the highest resistance to heat and corrosion are alloy steels, especially austenitic steel. The conditions that trigger cavitation may be assessed by calculating the total net suction head, referred to in technical literature with the acronym NPSH (Net Positive Suction Head).

The NPSH represents the total energy (expressed in m.) of the liquid measured at suction under conditions of incipient cavitation, excluding the vapour pressure (expressed in m.) that the liquid has at the pump inlet.

To find the static height h_z at which to install the machine under safe conditions, the following formula must be verified:

$$h_p + h_z \geq (\text{NPSH}_r + 0.5) + h_f + h_{pv} \quad \textcircled{1}$$

where:

- h_p** is the absolute pressure applied to the free liquid surface in the suction tank, expressed in m. of liquid; h_p is the quotient between the barometric pressure and the specific weight of the liquid.
- h_z** is the suction lift between the pump axis and the free liquid surface in the suction tank, expressed in m.; h_z is negative when the liquid level is lower than the pump axis.
- h_f** is the flow resistance in the suction line and its accessories, such as: fittings, foot valve, gate valve, elbows, etc.
- h_{pv}** is the vapour pressure of the liquid at the operating temperature, expressed in m. of liquid. h_{pv} is the quotient between the Pv vapour pressure and the liquid's specific weight.
- 0,5** is the safety factor.

The maximum possible suction head for installation depends on the value of the atmospheric pressure (i.e. the elevation above sea level at which the pump is installed) and the temperature of the liquid.

To help the user, with reference to water temperature (4° C) and to the elevation above sea level, the following tables show the drop in hydraulic pressure head in relation to the elevation above sea level, and the suction loss in relation to temperature.

Water temperature (°C)	20	40	60	80	90	110	120
Suction loss (m)	0,2	0,7	2,0	5,0	7,4	15,4	21,5

Elevation above sea level (m)	500	1000	1500	2000	2500	3000
Suction loss (m)	0,55	1,1	1,65	2,2	2,75	3,3

Friction loss is shown in the tables at pages 50-51 of this catalogue. To reduce it to a minimum, especially in cases of high suction head (over 4-5 m.) or within the operating limits with high flow rates, we recommend using a suction line having a larger diameter than that of the pump's suction port. It is always a good idea to position the pump as close as possible to the liquid to be pumped.

Make the following calculation:

Liquid: water at ~15°C $\gamma = 1 \text{ kg/dm}^3$

Flow rate required: 30 m³/h

Head for required delivery: 43 m.

Suction lift: 3,5 m.

The selection is an FHE 40-200/75 pump whose NPSH required value is, at 30 m³/h, di 2,5 m.

For water at 15 °C

$$h_p = P_a / \gamma = 10,33\text{m}, h_{pv} = P_v / \gamma = 0,174\text{m} (0,01701 \text{ bar})$$

The H_f flow resistance in the suction line with foot valves is ~ 1,2 m.

By substituting the parameters in formula $\textcircled{1}$ with the numeric values above, we have:

$$10,33 + (-3,5) \geq (2,5 + 0,5) + 1,2 + 0,17$$

from which we have: 6,8 > 4,4

The relation is therefore verified.



TECHNICAL APPENDIX VAPOUR PRESSURE PS VAPOUR PRESSURE AND ρ DENSITY OF WATER TABLE

t °C	T K	ps bar	ρ kg/dm ³	t °C	T K	ps bar	ρ kg/dm ³	t °C	T K	ps bar	ρ kg/dm ³
0	273,15	0,00611	0,9998	55	328,15	0,15741	0,9857	120	393,15	1,9854	0,9429
1	274,15	0,00657	0,9999	56	329,15	0,16511	0,9852	122	395,15	2,1145	0,9412
2	275,15	0,00706	0,9999	57	330,15	0,17313	0,9846	124	397,15	2,2504	0,9396
3	276,15	0,00758	0,9999	58	331,15	0,18147	0,9842	126	399,15	2,3933	0,9379
4	277,15	0,00813	1,0000	59	332,15	0,19016	0,9837	128	401,15	2,5435	0,9362
5	278,15	0,00872	1,0000	60	333,15	0,1992	0,9832	130	403,15	2,7013	0,9346
6	279,15	0,00935	1,0000	61	334,15	0,2086	0,9826	132	405,15	2,867	0,9328
7	280,15	0,01001	0,9999	62	335,15	0,2184	0,9821	134	407,15	3,041	0,9311
8	281,15	0,01072	0,9999	63	336,15	0,2286	0,9816	136	409,15	3,223	0,9294
9	282,15	0,01147	0,9998	64	337,15	0,2391	0,9811	138	411,15	3,414	0,9276
10	283,15	0,01227	0,9997	65	338,15	0,2501	0,9805	140	413,15	3,614	0,9258
11	284,15	0,01312	0,9997	66	339,15	0,2615	0,9799	145	418,15	4,155	0,9214
12	285,15	0,01401	0,9996	67	340,15	0,2733	0,9793	155	428,15	5,433	0,9121
13	286,15	0,01497	0,9994	68	341,15	0,2856	0,9788	160	433,15	6,181	0,9073
14	287,15	0,01597	0,9993	69	342,15	0,2984	0,9782	165	438,15	7,008	0,9024
15	288,15	0,01704	0,9992	70	343,15	0,3116	0,9777	170	443,15	7,920	0,8973
16	289,15	0,01817	0,9990	71	344,15	0,3253	0,9770	175	448,15	8,924	0,8921
17	290,15	0,01936	0,9988	72	345,15	0,3396	0,9765	180	453,15	10,027	0,8869
18	291,15	0,02062	0,9987	73	346,15	0,3543	0,9760	185	458,15	11,233	0,8815
19	292,15	0,02196	0,9985	74	347,15	0,3696	0,9753	190	463,15	12,551	0,8760
20	293,15	0,02337	0,9983	75	348,15	0,3855	0,9748	195	468,15	13,987	0,8704
21	294,15	0,24850	0,9981	76	349,15	0,4019	0,9741	200	473,15	15,550	0,8647
22	295,15	0,02642	0,9978	77	350,15	0,4189	0,9735	205	478,15	17,243	0,8588
23	296,15	0,02808	0,9976	78	351,15	0,4365	0,9729	210	483,15	19,077	0,8528
24	297,15	0,02982	0,9974	79	352,15	0,4547	0,9723	215	488,15	21,060	0,8467
25	298,15	0,03166	0,9971	80	353,15	0,4736	0,9716	220	493,15	23,198	0,8403
26	299,15	0,03360	0,9968	81	354,15	0,4931	0,9710	225	498,15	25,501	0,8339
27	300,15	0,03564	0,9966	82	355,15	0,5133	0,9704	230	503,15	27,976	0,8273
28	301,15	0,03778	0,9963	83	356,15	0,5342	0,9697	235	508,15	30,632	0,8205
29	302,15	0,04004	0,9960	84	357,15	0,5557	0,9691	240	513,15	33,478	0,8136
30	303,15	0,04241	0,9957	85	358,15	0,5780	0,9684	245	518,15	36,523	0,8065
31	304,15	0,04491	0,9954	86	359,15	0,6011	0,9678	250	523,15	39,776	0,7992
32	305,15	0,04753	0,9951	87	360,15	0,6249	0,9671	255	528,15	43,246	0,7916
33	306,15	0,05029	0,9947	88	361,15	0,6495	0,9665	260	533,15	46,943	0,7839
34	307,15	0,05318	0,9944	89	362,15	0,6749	0,9658	265	538,15	50,877	0,7759
35	308,15	0,05622	0,9940	90	363,15	0,7011	0,9652	270	543,15	55,058	0,7678
36	309,15	0,05940	0,9937	91	364,15	0,7281	0,9644	275	548,15	59,496	0,7593
37	310,15	0,06274	0,9933	92	365,15	0,7561	0,9638	280	553,15	64,202	0,7505
38	311,15	0,06624	0,9930	93	366,15	0,7849	0,9630	285	558,15	69,186	0,7415
39	312,15	0,06991	0,9927	94	367,15	0,8146	0,9624	290	563,15	74,461	0,7321
40	313,15	0,07375	0,9923	95	368,15	0,8453	0,9616	295	568,15	80,037	0,7223
41	314,15	0,07777	0,9919	96	369,15	0,8769	0,9610	300	573,15	85,927	0,7122
42	315,15	0,08198	0,9915	97	370,15	0,9094	0,9602	305	578,15	92,144	0,7017
43	316,15	0,09639	0,9911	98	371,15	0,9430	0,9596	310	583,15	98,70	0,6906
44	317,15	0,09100	0,9907	99	372,15	0,9776	0,9586	315	588,15	105,61	0,6791
45	318,15	0,09582	0,9902	100	373,15	1,0133	0,9581	320	593,15	112,89	0,6669
46	319,15	0,10086	0,9898	102	375,15	1,0878	0,9567	325	598,15	120,56	0,6541
47	320,15	0,10612	0,9894	104	377,15	1,1668	0,9552	330	603,15	128,63	0,6404
48	321,15	0,11162	0,9889	106	379,15	1,2504	0,9537	340	613,15	146,05	0,6102
49	322,15	0,11736	0,9884	108	381,15	1,3390	0,9522	350	623,15	165,35	0,5743
50	323,15	0,12335	0,9880	110	383,15	1,4327	0,9507	360	633,15	186,75	0,5275
51	324,15	0,12961	0,9876	112	385,15	1,5316	0,9491	370	643,15	210,54	0,4518
52	325,15	0,13613	0,9871	114	387,15	1,6362	0,9476	374,15	647,30	221,20	0,3154
53	326,15	0,14293	0,9862	116	389,15	1,7465	0,9460				
54	327,15	0,15002	0,9862	118	391,15	1,8628	0,9445				

G-at_nps_h_a_sc

FLOW RESISTANCE
TABLE OF FLOW RESISTANCE IN BENDS, VALVES AND GATES

The flow resistance is calculated using the equivalent pipeline length method according to the table below:

ACCESSORY TYPE	DN											
	25	32	40	50	65	80	100	125	150	200	250	300
	Equivalent pipeline length (m)											
45° bend	0,2	0,2	0,4	0,4	0,6	0,6	0,9	1,1	1,5	1,9	2,4	2,8
90° bend	0,4	0,6	0,9	1,1	1,3	1,5	2,1	2,6	3,0	3,9	4,7	5,8
90° smooth bend	0,4	0,4	0,4	0,6	0,9	1,1	1,3	1,7	1,9	2,8	3,4	3,9
Union tee or cross	1,1	1,3	1,7	2,1	2,6	3,2	4,3	5,3	6,4	7,5	10,7	12,8
Gate	-	-	-	0,2	0,2	0,2	0,4	0,4	0,6	0,9	1,1	1,3
Non return valve	1,1	1,5	1,9	2,4	3,0	3,4	4,7	5,9	7,4	9,6	11,8	13,9

G-a-pcv_a_th

The table is valid for the Hazen Williams coefficient $C = 100$ (cast iron pipework). For steel pipework, multiply the values by 1.41. For stainless steel, copper and coated cast iron pipework, multiply the values by 1.85.

When the **equivalent pipeline length** has been determined, the flow resistance is obtained from the table of flow resistance.

The values given are guideline values which are bound to vary slightly according to the model, especially for gate valves and non-return valves, for which it is a good idea to check the values supplied by the manufacturers.



VOLUMETRIC CAPACITY

Litres per minute l/min	Cubic metres per hour m ³ /h	Cubic feet per hour ft ³ /h	Cubic feet per minute ft ³ /min	Imp. gal. per minute Imp. gal./min	US gal. per minute Us gal./min
1,000	0,0600	2,1189	0,0353	0,2200	0,2642
16,6667	1,0000	35,3147	0,5886	3,6662	4,4029
0,4719	0,0283	1,0000	0,0167	0,1038	0,1247
28,3168	1,6990	60,0000	1,0000	6,2288	7,4805
4,5461	0,2728	9,6326	0,1605	1,0000	1,2009
3,7854	0,2271	8,0208	0,1337	0,8327	1,0000

PRESSURE AND HEAD

Newton per square metre N/m ²	kilo Pascal kPa	bar bar	Pound force per square inch psi	metre of water m H ₂ O	millimetre of mercury mm Hg
1,0000	0,0010	1 x 10 ⁻⁵	1.45 x 10 ⁻⁴	1.02 x 10 ⁻⁴	0,0075
1000,0000	1,0000	0,0100	0,1450	0,1020	7,5006
1 x 10 ⁵	100,0000	1,0000	14,5038	10,1972	750,0638
6894,7570	6,8948	0,0689	1,0000	0,7031	51,7151
9806,6500	9,8067	0,0981	1,4223	1,0000	73,5561
133,3220	0,1333	0,0013	0,0193	0,0136	1,0000

LENGHT

millimetre mm	centimetre cm	metre m	inch in	foot ft	yard yd
1,0000	0,1000	0,0010	0,0394	0,0033	0,0011
10,0000	1,0000	0,0100	0,3937	0,0328	0,0109
1000,0000	100,0000	1,0000	39,3701	3,2808	1,0936
25,4000	2,5400	0,0254	1,0000	0,0833	0,0278
304,8000	30,4800	0,3048	12,0000	1,0000	0,3333
914,4000	91,4400	0,9144	36,0000	3,0000	1,0000

VOLUME

cubic metre m ³	litre litro	millilitre ml	imp. Gallon imp. gal.	US gallon US gal.	cubic foot ft ³
1,0000	1000,0000	1 x 10 ⁶	219,9694	264,1720	35,3147
0,0010	1,0000	1000,0000	0,2200	0,2642	0,0353
1 x 10 ⁻⁶	0,0010	1,0000	2.2 x 10 ⁻⁴	2.642 x 10 ⁻⁴	3.53 x 10 ⁻⁵
0,0045	4,5461	4546,0870	1,0000	1,2009	0,1605
0,0038	3,7854	3785,4120	0,8327	1,0000	0,1337
0,0283	28,3168	28316,8466	6,2288	7,4805	1,0000

G-at_pp-en_a_sc

FURTHER PRODUCT SELECTION AND DOCUMENTATION

Select ITT

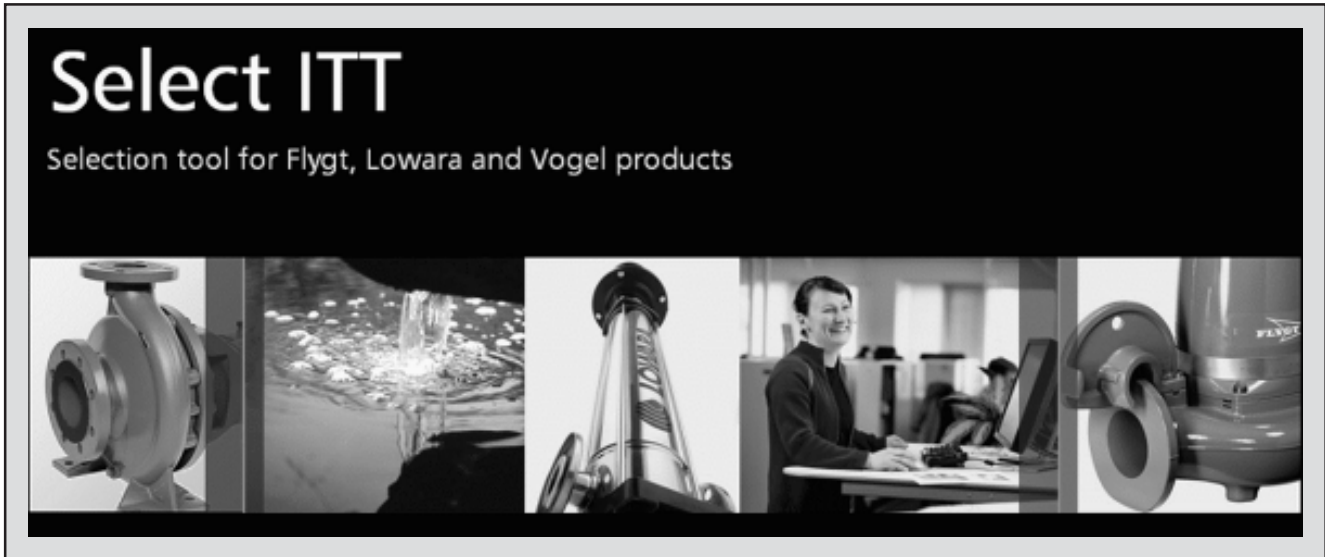

Select ITT is pump solution selection software with an extensive online database of product information across the entire Lowara, and Vogel range of pumps and related products, with multiple search options and helpful project management facilities. The system holds up-to-date product information on thousands of products and accessories.

The possibility to search by applications and the detailed information output given makes it easy to make the optimal selection without having detailed knowledge about the Lowara and Vogel products.

The search can be made by:

- Application
- Product type
- Duty point

Select ITT gives a detailed output:

- List with search results
- Performance curves (flow, head, power, efficiency, NPSH)
- Motor data
- Dimensional drawings
- Options
- Data sheet printouts
- Document downloads incl dxf files



The search by application guides users not familiar with the product range to the right choice.

FURTHER PRODUCT SELECTION AND DOCUMENTATION

Select ITT

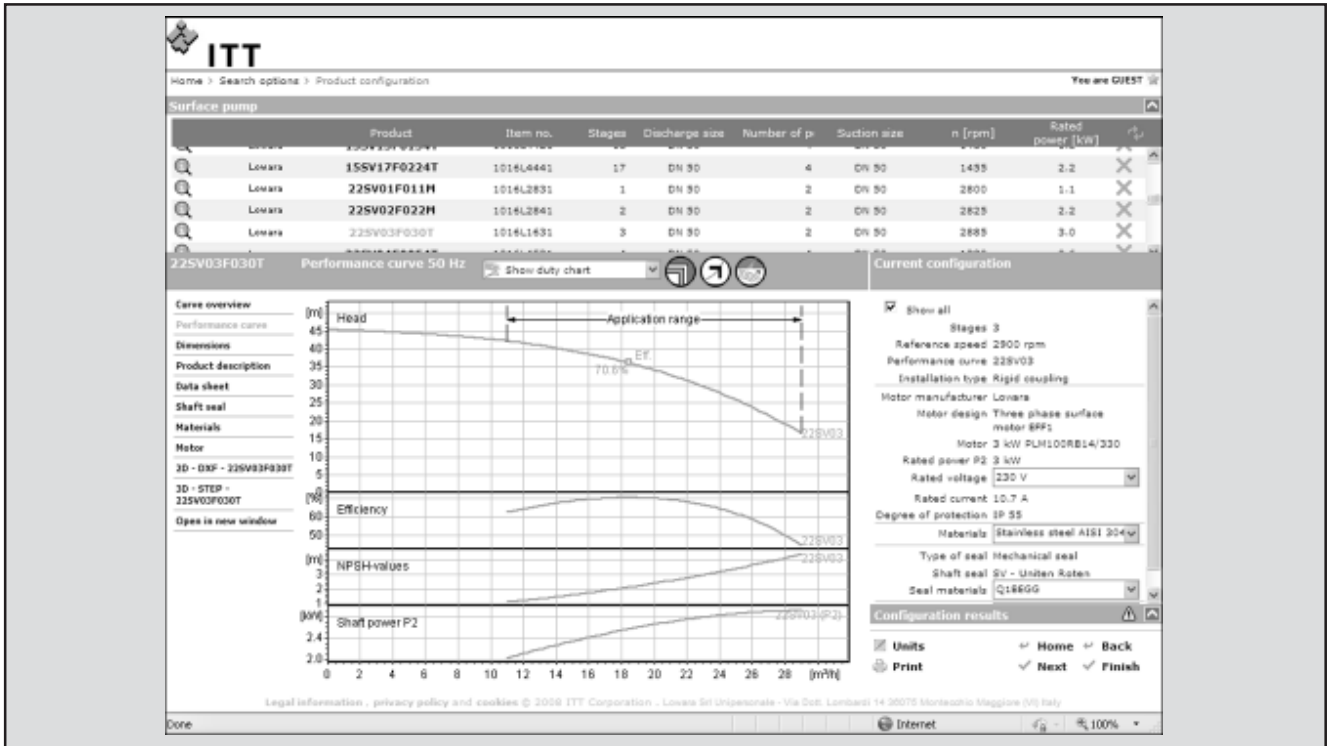

The detailed output makes it easy to select the optimal pump from the given alternatives.

The best way to work with Select ITT is to create a personal account. This makes it possible to:

- Set own standard units
- Create and save projects
- Share projects with other Select ITT users

Every user has a My Select ITT space, where all projects are saved.

For more information about Select ITT, contact ITT or visit www.selectitt.com to register for Select ITT online.

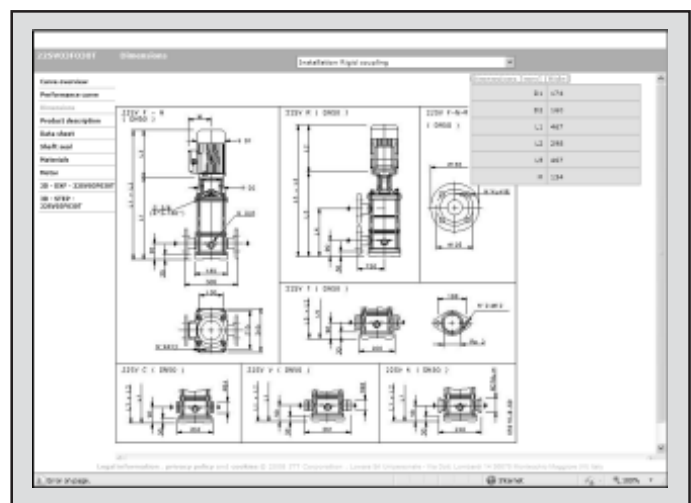

Dimensional drawings appear on the screen and can be downloaded in dxf format.

ITT-Lowara (www.lowara.com), headquarters of "Residential and Commercial Water - EMEA" part of the ITT Corporation and located in Montecchio Maggiore, Vicenza - Italy, is a leading manufacturer of hydraulic pumps and water handling and control systems. It has 1.616 employees in Europe, 671 operating in Italy. In 2010 its consolidated sales totalled about 306 million €, or over 404 million \$. ITT Corporation is a high-technology engineering and manufacturing company operating on all seven continents in three vital markets: water and fluids management, global defense and security, and motion and flow control. With a heritage of innovation, ITT partners with its customers to deliver extraordinary solutions that create more livable environments, provide protection and safety and connect our world. Headquartered in White Plains, N.Y., the company generated 2010 revenue of \$11.0 billion.

ITT RESIDENTIAL AND COMMERCIAL WATER DIVISION - EMEA**Headquarters**

LOWARA S.r.l. Unipersonale
Via Dott. Lombardi, 14
36075 Montecchio Maggiore
Vicenza - Italy
Tel. (+39) 0444 707111
Fax (+39) 0444 492166
e-mail: lowara.mkt@itt.com
<http://www.lowara.com>

AUSTRIA
ITT AUSTRIA GmbH
A-2000 STOCKERAU
Ernst Vogel-Straße 2
Tel. (+43) 02266 604
Fax (+43) 02266 65311
e-mail: info.ittaustria@itt.com
<http://www.ittaustria.com>

FRANCE
ITT FRANCE
Parc de l'île
29 rue du Port
92022 Nanterre Cedex
Tel. (+33) 02 47 88 17 17
Fax (+33) 02 47 88 17 00
e-mail: lowarafr.info@itt.com
<http://www.lowara.fr>

GERMANY
ITT LOWARA DEUTSCHLAND GmbH
Biebigheimer Straße 12
D-63762 Grobostheim
Tel. (+49) 0 60 26 9 43 - 0
Fax (+49) 0 60 26 9 43 - 2 10
e-mail: info.lowarade@itt.com
<http://www.lowara.de>

IRELAND
ITT IRELAND
50 Broomhill Close
Airton Road
Tallaght
DUBLIN 24
Tel. (+353) 01 4524444
Fax (+353) 01 4524795
e-mail: lowara.ireland@itt.com -
<http://www.lowara.ie>

NEDERLAND
LOWARA NEDERLAND B.V.
Zandweistraat 22
4181 CG Waardenburg
Tel. (+31) 0418 65 50 60
Fax (+31) 0418 65 50 61
e-mail: sales.nl@itt.com
<http://www.lowara.nl>

POLAND
LOWARA VOGEL POLSKA Sp. z o.o.
PL 57-100 Strzelin
ul. Kazimierza Wielkiego 5
Tel. (+48) 071 769 3900 - Fax (+48) 071 769 3909
e-mail: info.lowarapl@itt.com -
<http://www.lowara-voegel.pl>

PORTUGAL
ITT PORTUGAL, Lda
Praceta da Castanheira, 38
4475-019 Barca
Tel. (+351) 22 9478550
Fax (+351) 22 9478570
e-mail: info.pt@itt.com
<http://www.itt.pt>

RUSSIA
LOWARA RUSSIA
Kalanchevskaya st. 11 b.2, off. 334
107078 Moscow
Tel. (+7) 495 631 55 15
Fax (+7) 495 631 59 72
info.lowararu@itt.com - www.lowara.ru

UK
LOWARA UK LTD.
Millwey Rise, Industrial Estate
Axminster - Devon EX13 5HU UK
Tel. (+44) 01297 630200
Fax (+44) 01297 630270
e-mail: lowaraukenquiries@itt.com
<http://www.lowara.co.uk>

For additional addresses, please visit
www.lowara.com

cod. 191002451 W 06/11

*Lowara reserves the right to make modifications
without prior notice.*